

INTEGRAL PCC CURB AND GUTTER
TYPE 1-8

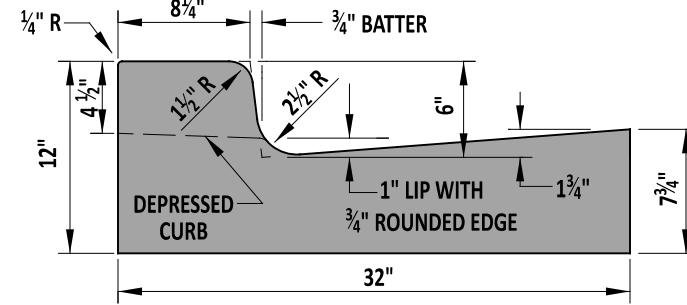

INTEGRAL PCC CURB AND GUTTER
TYPE 1-6

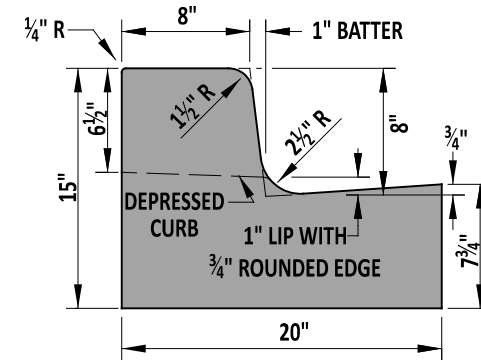

INTEGRAL PCC CURB AND GUTTER
TYPE 3-8

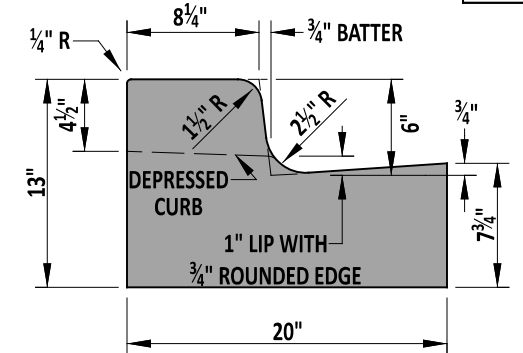

INTEGRAL PCC CURB AND GUTTER
TYPE 3-6

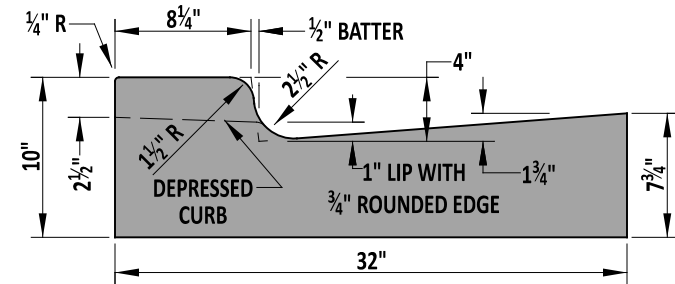

INTEGRAL PCC CURB AND GUTTER
TYPE 1-4

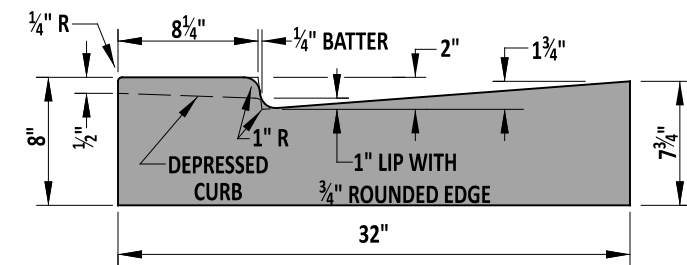

INTEGRAL PCC CURB AND GUTTER
TYPE 1-2

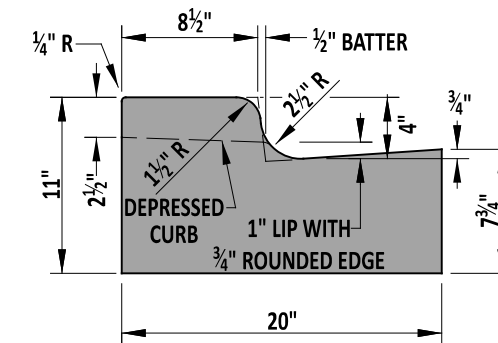

INTEGRAL PCC CURB AND GUTTER
TYPE 3-4

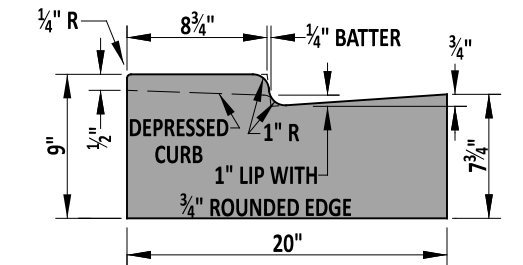

INTEGRAL PCC CURB AND GUTTER
TYPE 3-2

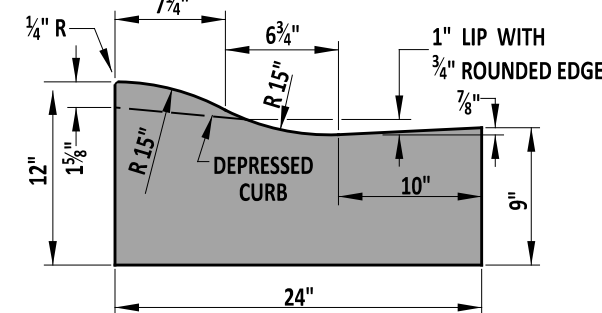

INTEGRAL PCC CURB AND GUTTER
TYPE 2

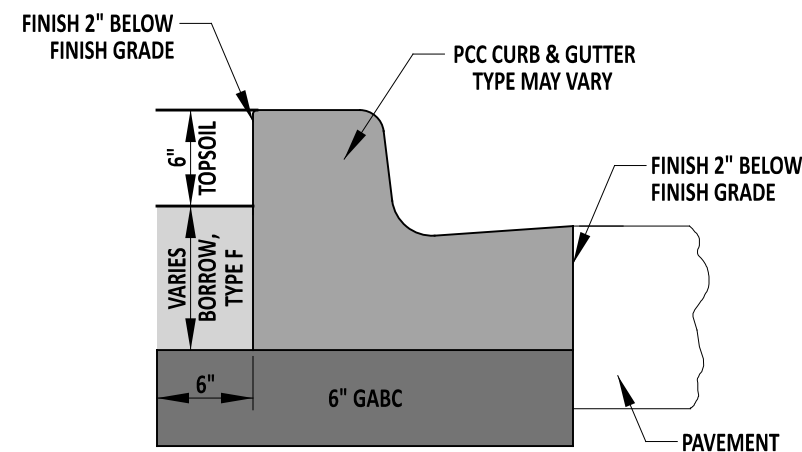

TYPICAL PCC CURB AND GUTTER SECTION

NOTES:

- 1). WHEN PCC CURB OR INTEGRAL PCC CURB AND GUTTER IS PLACED ADJACENT TO PORTLAND CEMENT CONCRETE PAVEMENT, CONSTRUCT THE JOINT AS PER THE LONGITUDINAL JOINT SEALANT DETAIL ON DETAIL P-2, SHEET 3 OF 5. USE APPROVED JOINT FILLER TO SEAL. WORK TO BE PAID UNDER RESPECTIVE CURB AND GUTTER ITEM.
- 2). THE DEPRESSED CURB DIMENSIONS (INCLUDING 1" LIP) ON THIS SHEET ARE FOR USE AT ENTRANCES ONLY. FOR CURB DIMENSIONS AT PEDESTRIAN CONNECTION, SEE NOTE 3.
- 3). SEE DETAIL C-1, SHEET 3 FOR DEPRESSING AT PEDESTRIAN CONNECTION.
- 4). DEPRESS CURB FLUSH WITH PAVEMENT OR ADJACENT AREA AT LEADING EDGE OF TRIANGULAR ISLANDS, TAPERING BACK TO FULL HEIGHT AT A SLOPE OF 4:1. SEE C-1, SHEET 1 OF 4 FOR TYPICAL SECTION OF TAPER AT NOSE OF MEDIAN ISLANDS.
- 5). DEPRESS END OF CURB RUNS NOT PART OF AN ISLAND OR MEDIAN FLUSH WITH PAVEMENT OR ADJACENT AREA AT A SLOPE OF 12:1.
- 6). INSTALL TYPE IV POLYURETHANE-BONDED RECYCLED RUBBER EXPANSION MATERIAL BETWEEN THE FACE OF CURB AND EDGE OF PCC PAVEMENT.



John C. [Signature]
ENGINEERING SUPPORT
RECOMMENDED
DATE 12/03/2021

INTEGRAL PCC CURB & GUTTER
STANDARD NO. C-1 (2021)
SHT. 2 OF 4

REVIEWED
DEPUTY DIRECTOR - DESIGN
DATE 12/06/2021
APPROVED
CHIEF ENGINEER
DATE 12/07/2021