

PLAN VIEW

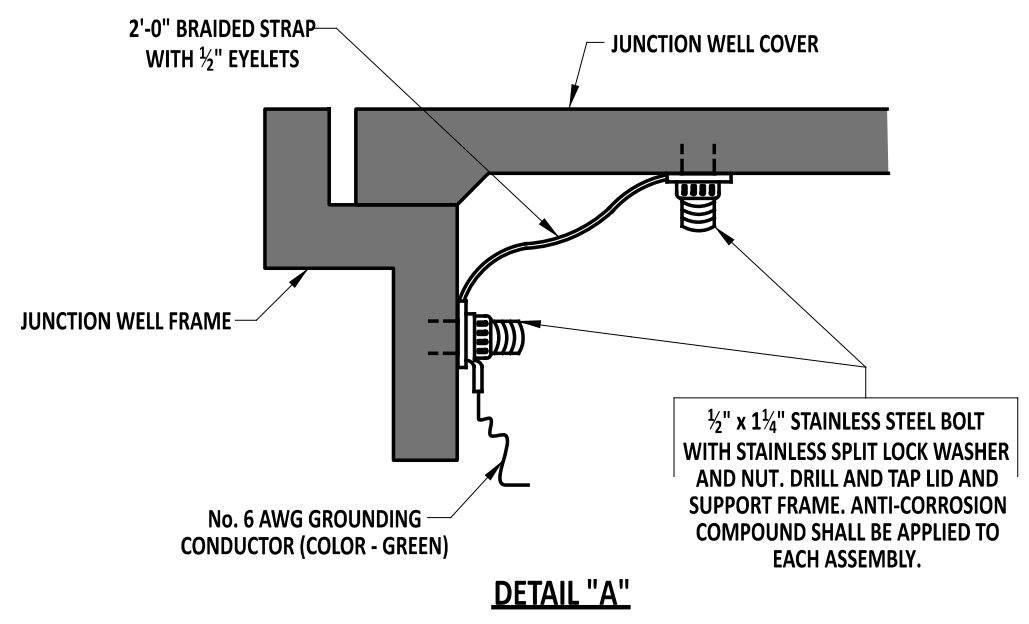

DETAIL "A"

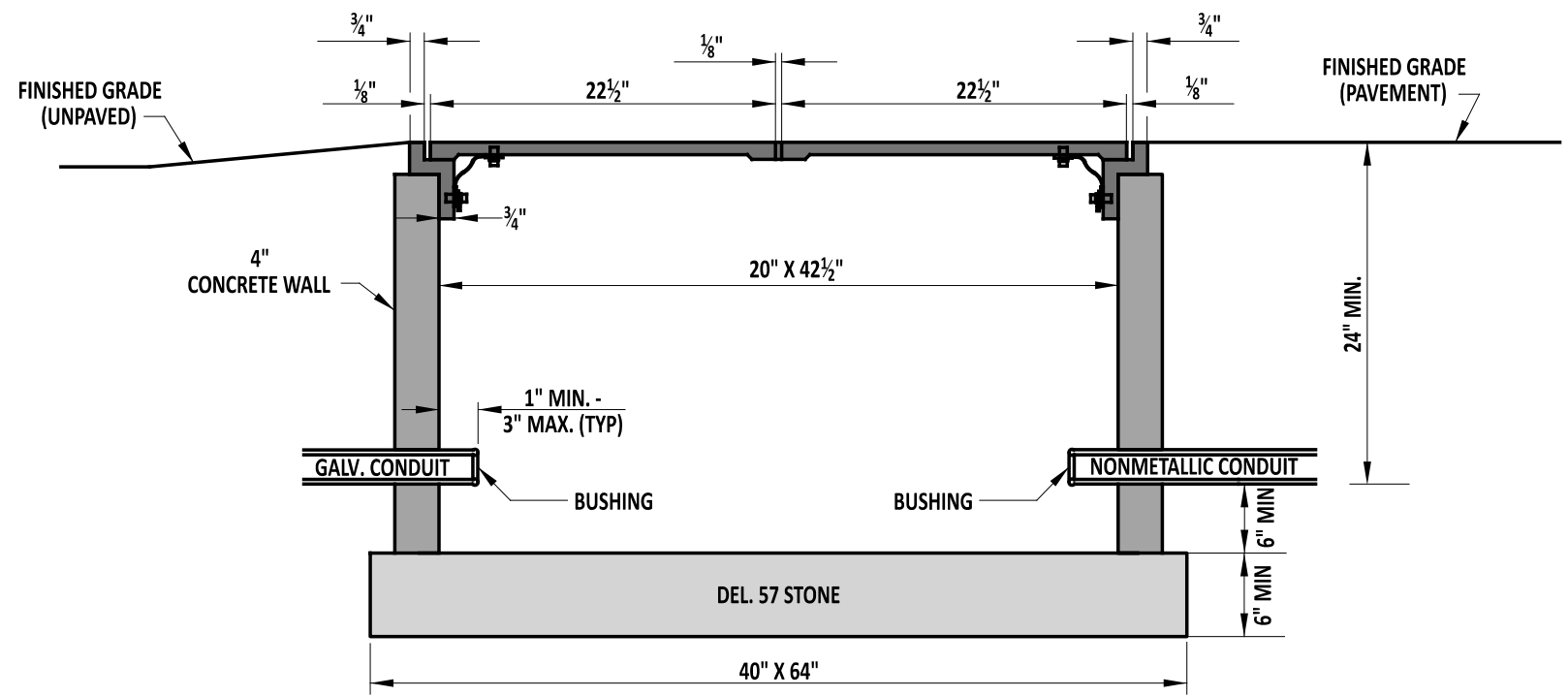

SECTION A-A

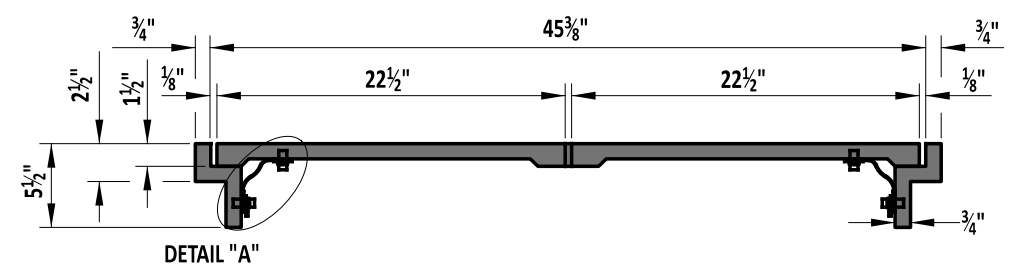

NOTES:

- 1). TYPE 4 CONDUIT JUNCTION WELL SHALL BE PRECAST CONCRETE. AT LEAST ONE HOLE IN PRECAST WELLS WILL BE OF A 5" DIAMETER COMPLETELY THROUGH THE WALL. UNUSED HOLES SHALL BE PLUGGED.
- 2). ALL CONDUIT JUNCTION WELLS PLACED IN PAVED AREAS SHALL BE CONSTRUCTED FLUSH WITH THE FINISHED GRADE. ALL CONDUIT JUNCTION WELLS PLACED IN UNPAVED AREAS SHALL BE CONSTRUCTED ABOVE FINISHED GRADE, AND GRADED TO DRAIN AWAY FROM THE WELL, AS DETAILED.
- 3). ALL CRACKS, GAPS, OR OPENINGS IN JUNCTION WELL WALL SHALL BE SEALED WITH CONCRETE.
- 4). AREA AROUND THE JUNCTION WELL SHALL BE BACKFILLED WITH BORROW TYPE C MATERIAL TO THE REQUIRED ELEVATION IN ACCORDANCE WITH SECTION 207. EXCESS AND UNSUITABLE MATERIAL SHALL BE DISPOSED PER SECTION 106.8.

	 ENGINEERING SUPPORT DATE 09/01/2020	CONDUIT JUNCTION WELL, TYPE 4		REVIEWED DEPUTY DIRECTOR - DESIGN DATE 09/01/2020
	RECOMMENDED	STANDARD NO. T-1 (2020)	SHT. 2 OF 4	APPROVED CHIEF ENGINEER DATE 09/01/2020