

NOTES:

- 1). SUPPORT LONGITUDINAL STEEL IN PLACE BY CRADLES.
- 2). COUNTERSINK LETTERS ON CONCRETE MONUMENT IN TOP OF MARKER 1/4".
- 3). USE FLEXIBLE DELINEATORS ONLY ON ROADS WITH A SPECIFIED DENIAL OF ACCESS OR CLASSIFIED AS MINOR ARTERIALS OR HIGHER. ON ALL OTHER ROAD CLASSIFICATIONS, PLACE A WOODEN STAKE WITH "ROW" HANDWRITTEN VERTICALLY IN 1" TALL LETTERS.
- 4). PLACE CAP ON CONCRETE MONUMENT SO THAT TOP OF CAP IS FLUSH WITH THE TOP OF THE CONCRETE MONUMENT.
- 5). DO NOT CHAMFER THE CONCRETE MONUMENT WHEN PLACED WITHIN BITUMINOUS OR PCC.

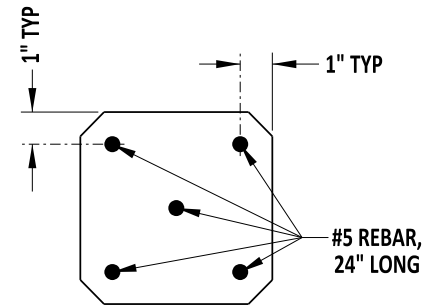
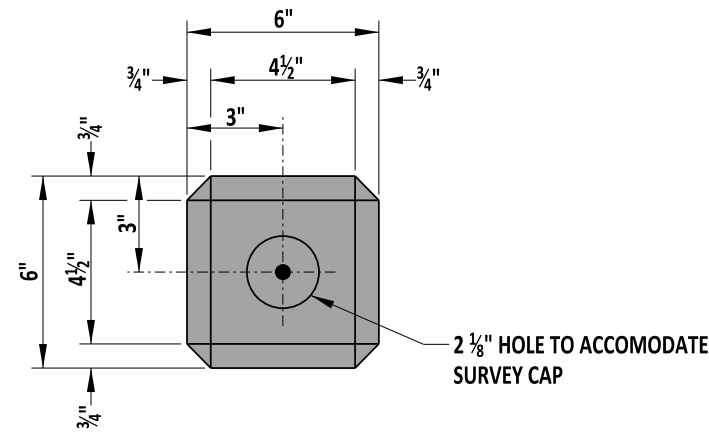

SECTION A-A

TOP

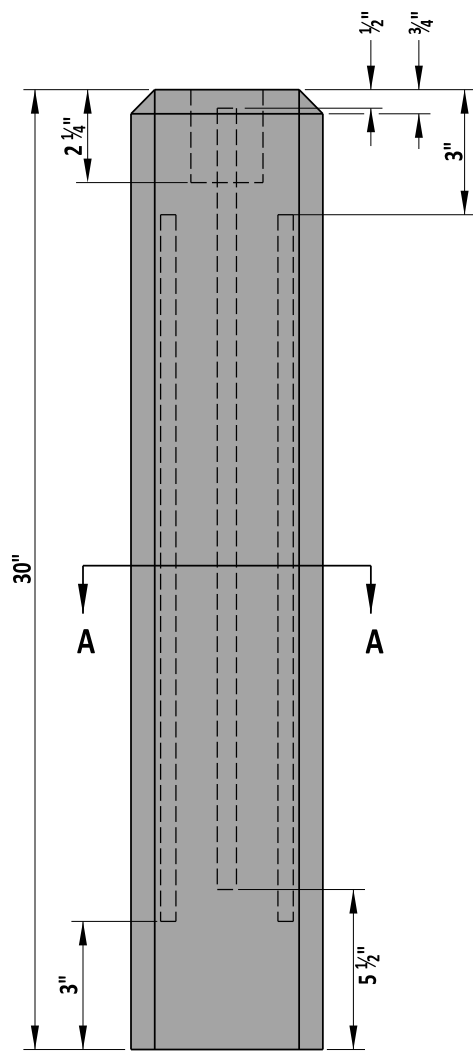

ELEVATION

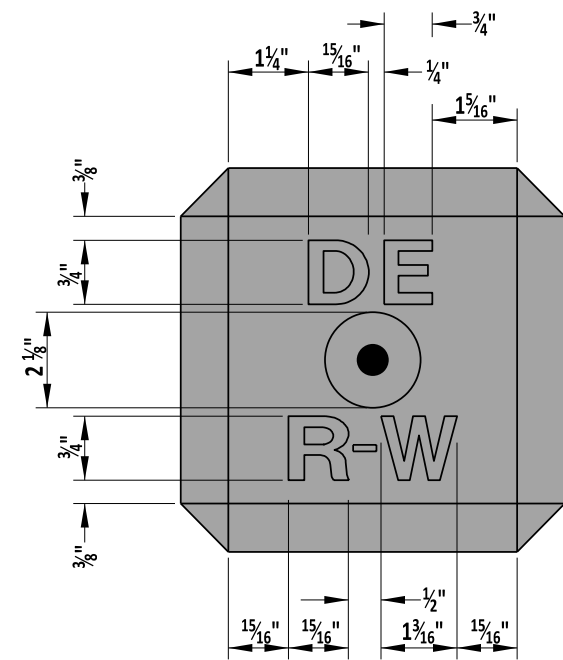

TOP DETAIL

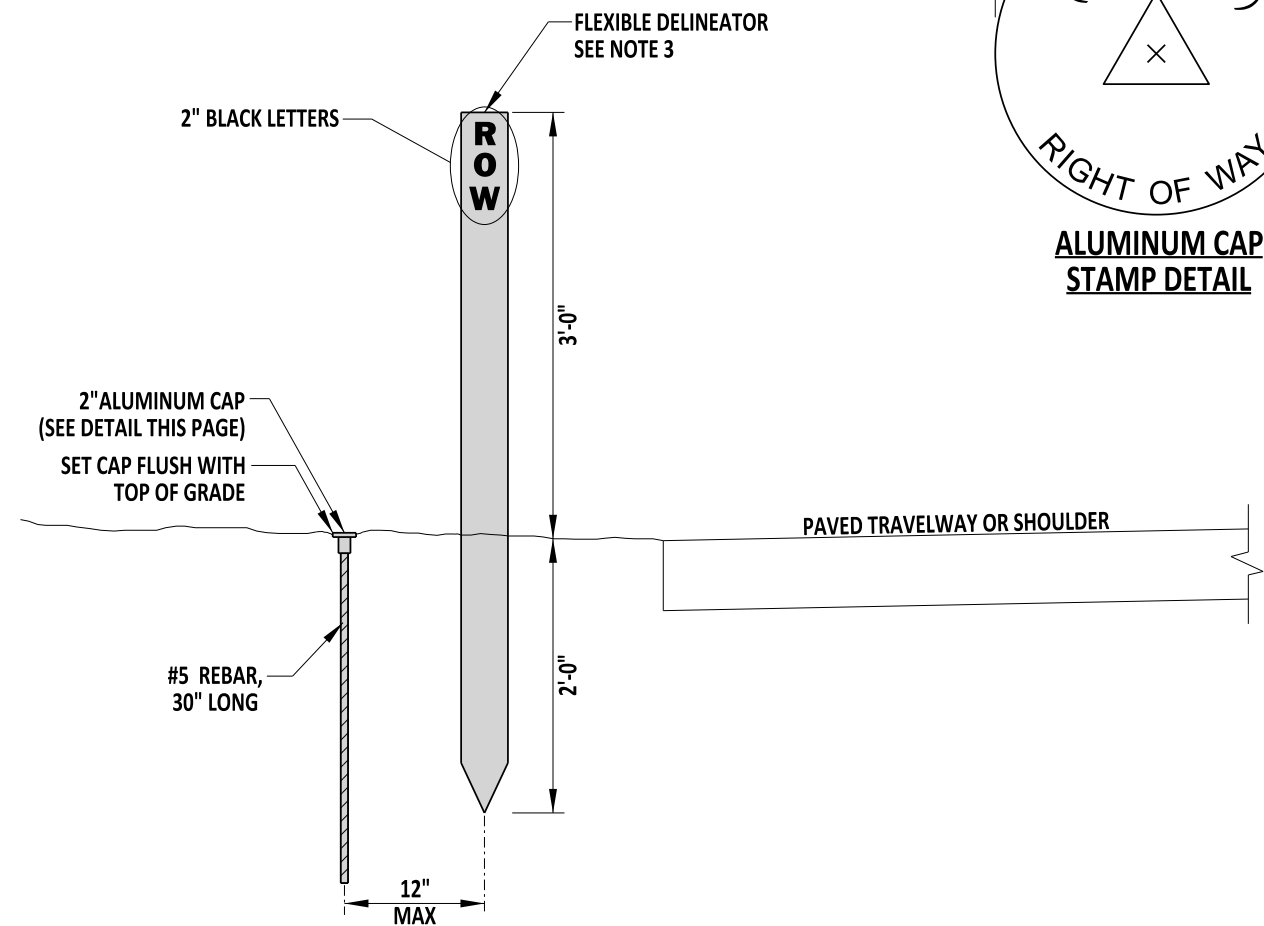

REBAR AND CAP WITH FLEXIBLE DELINEATOR DETAIL



ALUMINUM CAP STAMP DETAIL



 ENGINEERING SUPPORT DATE 09/01/2020
RECOMMENDED

RIGHT OF WAY MONUMENTATION

STANDARD NO. M-2 (2020) SHT. 1 OF 1

REVIEWED  DATE 09/01/2020
 APPROVED  DATE 09/01/2020