

**ANTI-SEEP COLLAR**

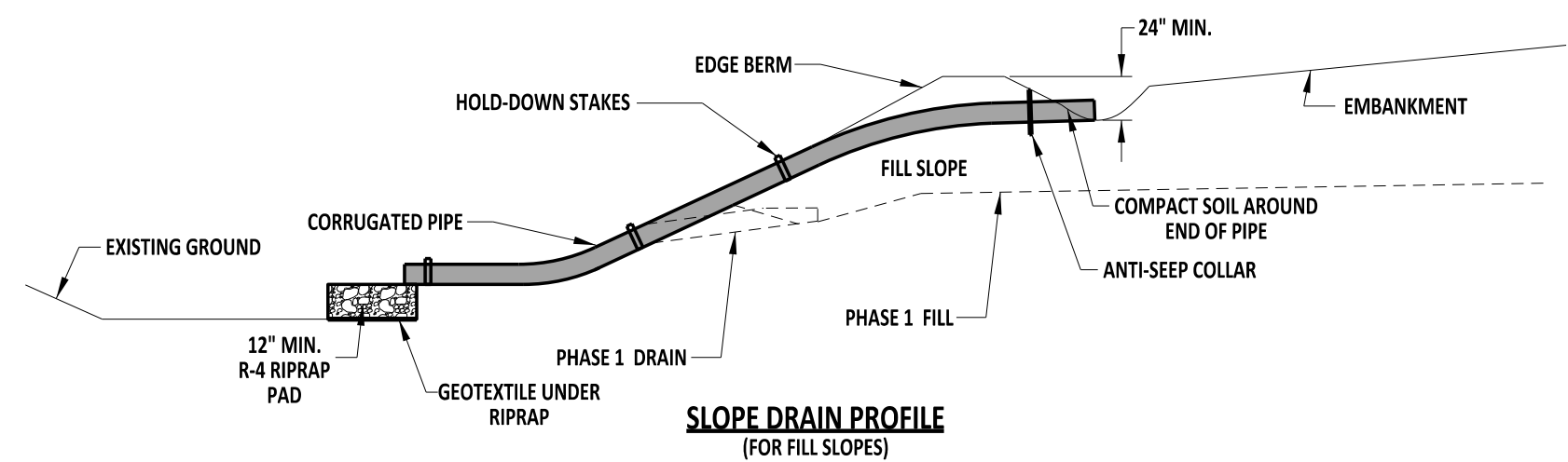

- NOTES:**
- 1). 15" PIPE FOR MAXIMUM DRAINAGE AREA OF ONE ACRE.
  - 2). DISCHARGE ALL TEMPORARY SLOPE DRAINS ONTO A STABILIZED OUTFALL AND THEN INTO A SEDIMENT TRAPPING DEVICE.
  - 3). USE TEMPORARY SLOPE DRAINS AT THE TOP OF FILL SLOPES AS EMBANKMENT IS CONSTRUCTED TO PREVENT EXCESSIVE EROSION UNTIL SHOULDERS ARE CONSTRUCTED AND THE SLOPES ARE SEEDING AS PER SPECIFICATIONS.
  - 4). FOR ALL TEMPORARY SLOPE DRAINS, USE A MINIMUM OF 3 HOLD DOWN STAKES SPACED EVENLY THROUGHOUT THE WHOLE LENGTH BEGINNING AT THE PIPE OUTLET INTO THE R-4 RIPRAP.



ENGINEERING SUPPORT  
*Paul Johnson*  
 09/01/2020  
 DATE  
**RECOMMENDED**

TEMPORARY SLOPE DRAIN  
 STANDARD NO. E-10 (2020)  
 SHT. 1 OF 1

REVIEWED  
*Mike Jones*  
 DEPUTY DIRECTOR - DESIGN  
 09/01/2020  
 DATE

APPROVED  
*Sheryl*  
 CHIEF ENGINEER  
 09/01/2020  
 DATE