

48" (1220) x 30" (760) INLET

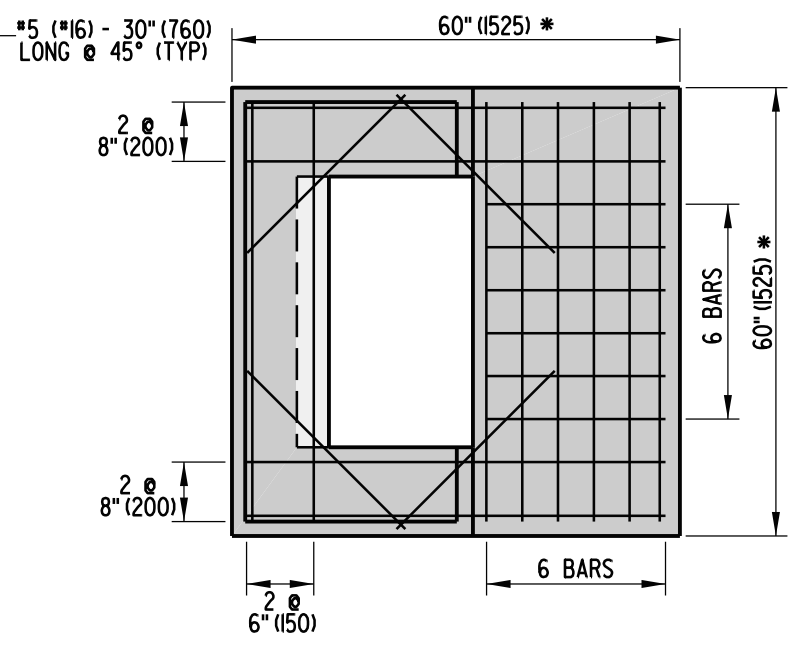

48" (1220) x 48" (1220) INLET

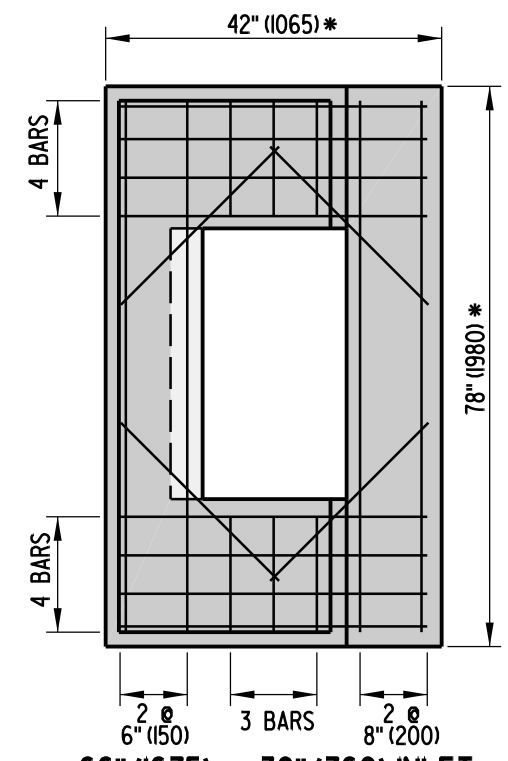

66" (1675) x 30" (760) INLET

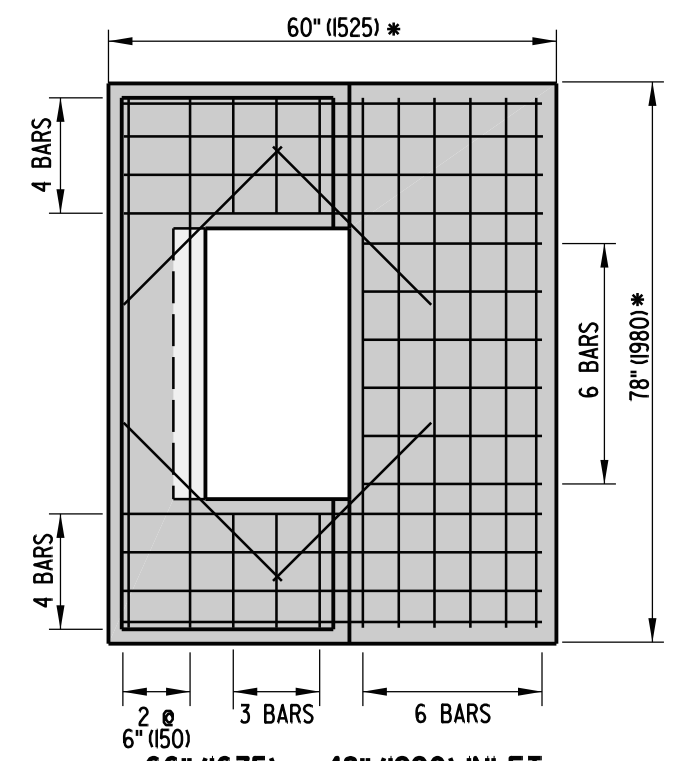

66" (1675) x 48" (1220) INLET

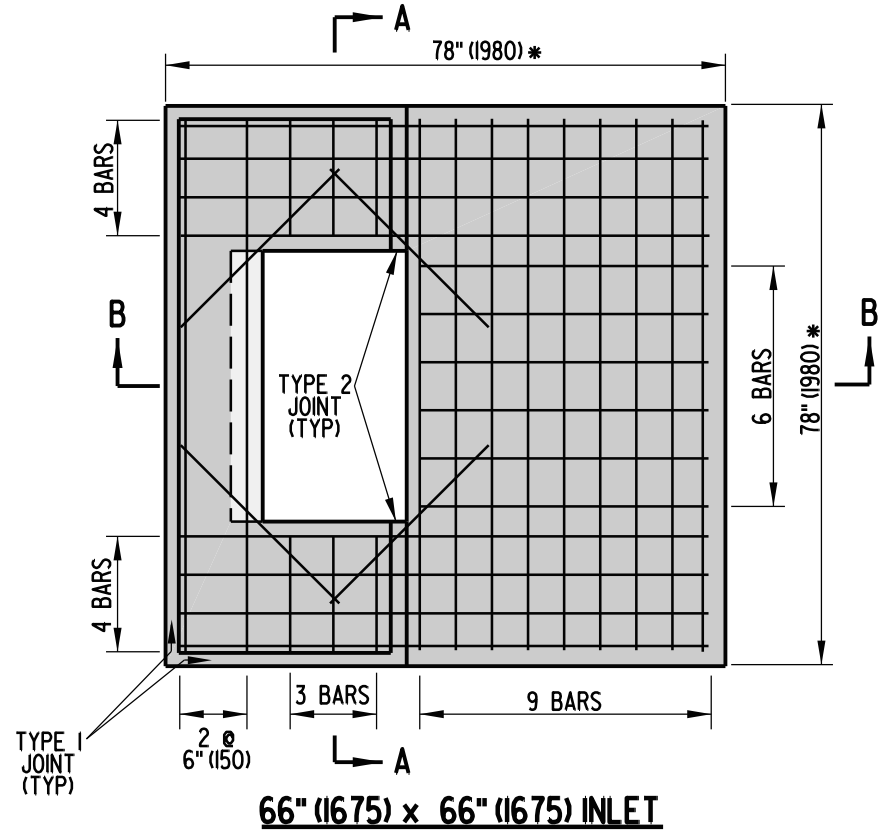

66" (1675) x 66" (1675) INLET

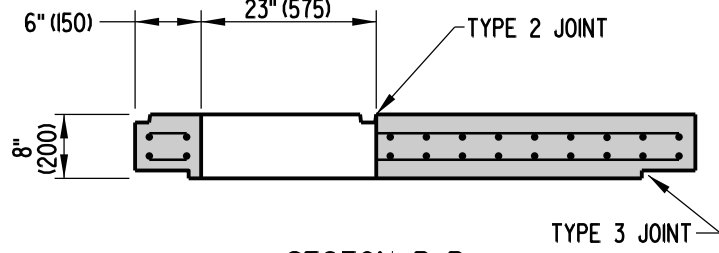

**SECTION B-B
FOR TYPE B TOP UNITS**

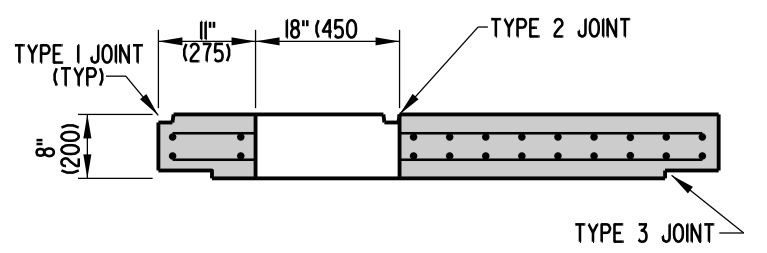

**SECTION B-B
FOR TYPES A, C, D, & E TOP UNITS**

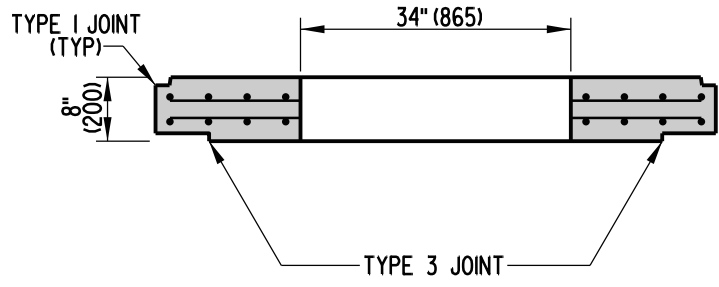

SECTION A-A

NOTES :

- 1). RELOCATE ENCROACHING REINFORCING BARS WHEN USING TYPE B UNIT.
- 2). COVER SLABS SHALL BE PRECAST AND MUST BE SIZED TO FIT INLET BOX DIMENSIONS.
- 3). ALL BARS ARE TO BE #5 (#16) SPACED @ 6" (150) UNLESS NOTED OTHERWISE. TOP REINFORCEMENT SHALL BE 0.11 IN² (70 mm²) HORIZONTAL REINFORCEMENT PER FOOT IN BOTH DIRECTIONS.
- 4). MINIMUM BAR COVER = 1 1/2" (38).

* - DIMENSIONS TO MATCH OUTSIDE TO OUTSIDE DIMENSIONS OF BOX.