

SCALE :

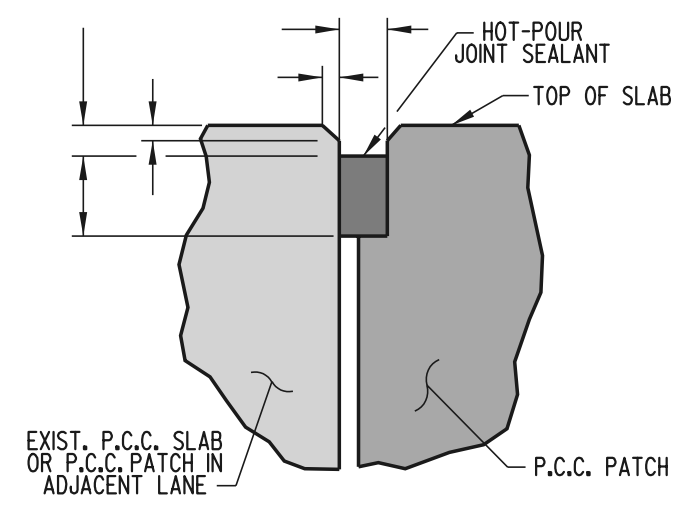

**SEALANT DETAIL -
LONGITUDINAL JOINT**

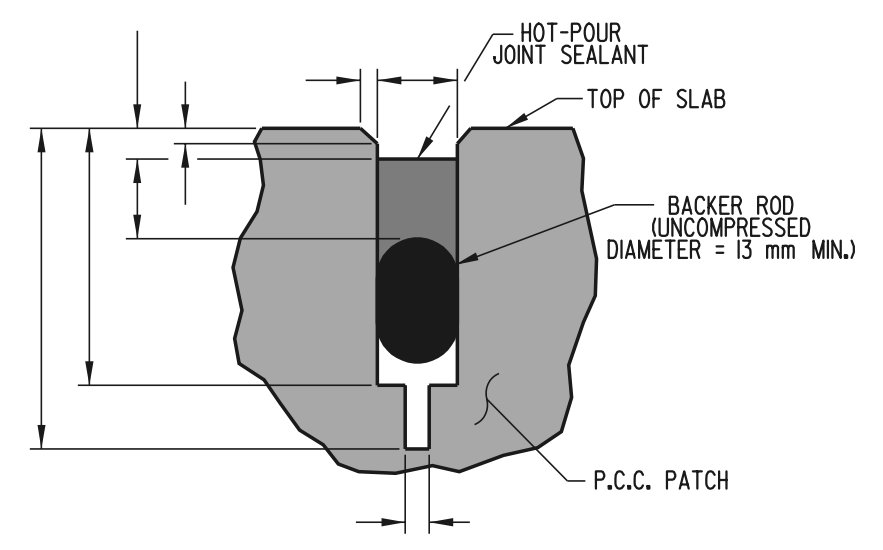

**SEALANT DETAIL -
TRANSVERSE SAW-CUT JOINT**

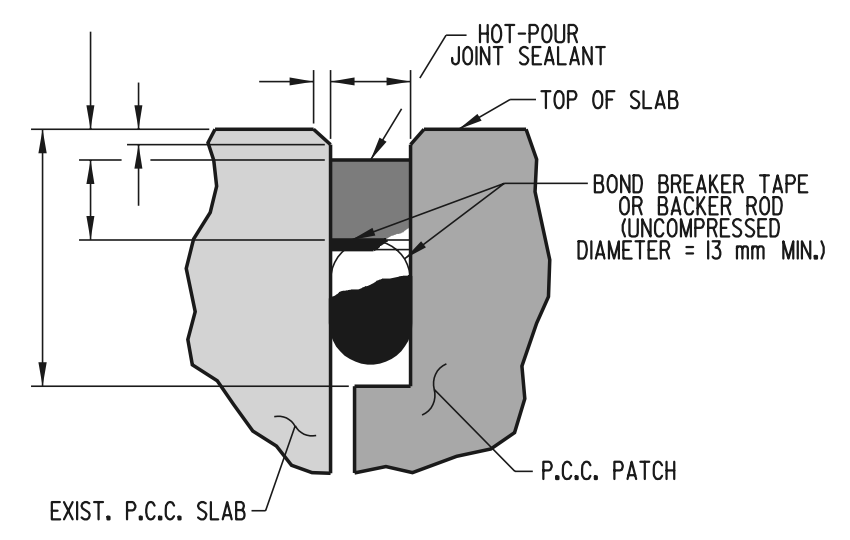

**SEALANT DETAIL -
TRANSVERSE CONSTRUCTION JOINT**

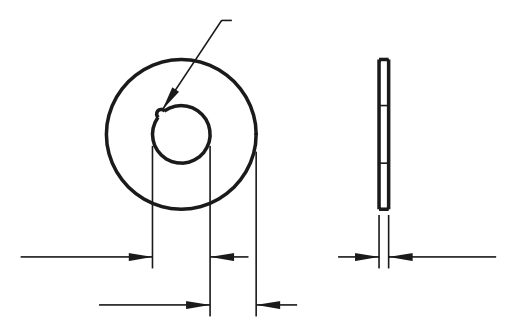

GROUT RETENTION DISK

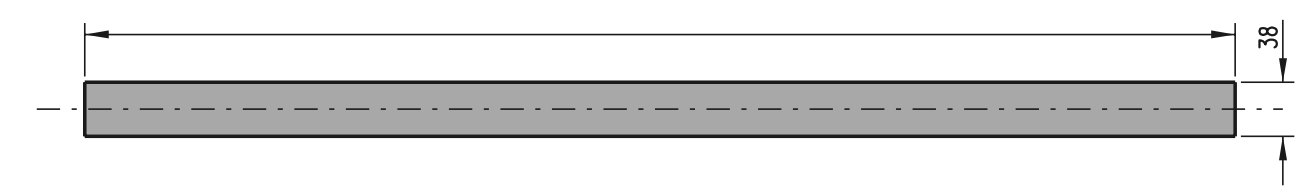

DOWEL BAR

NOTES:

- 2). "T" REFERS TO THE EXISTING "AS-BUILT" SLAB THICKNESS.
- 3). TOLERANCE ON ALL JOINT SEALANT DETAIL DIMENSIONS SHOWN WITHOUT RANGES SHALL BE PLUS 2 mm,
- 4). THE TOP EDGES OF THE CONTACT SURFACES OF THE SEALANT MATERIAL ON BOTH SIDES OF THE JOINT

FULL DEPTH PATCH

 DELAWARE DEPARTMENT OF TRANSPORTATION	P.C.C. PAVEMENT PATCHING			APPROVED
	STANDARD NO. P-02 (99)	SHT. 3	OF 5	<small>CHIEF ENGINEER</small> _____ <small>DATE</small> _____ RECOMMENDED <small>DESIGN ENGINEER</small> _____ <small>DATE</small> _____