

SCALE :

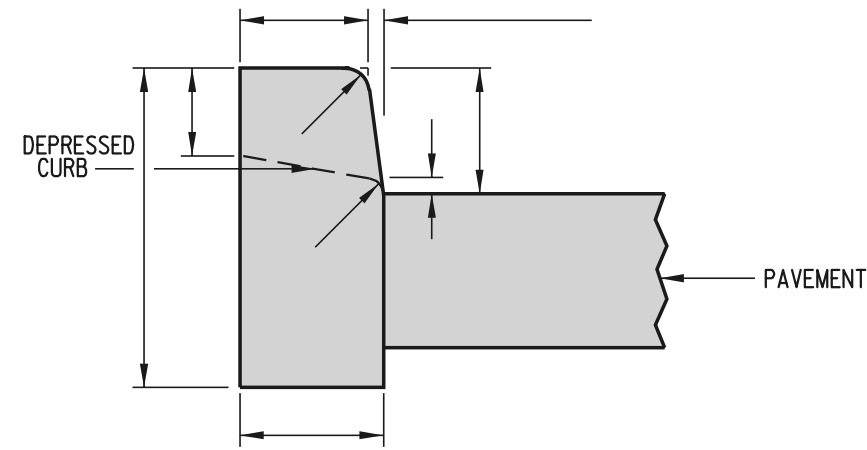

**P.C.C. CURB**  
TYPE 1

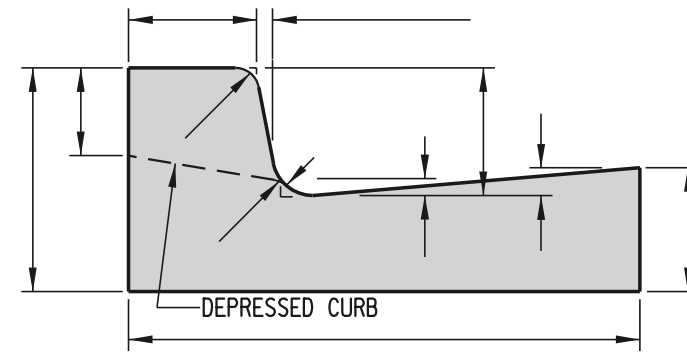

**INTEGRAL P.C.C. CURB AND GUTTER**  
TYPE 1

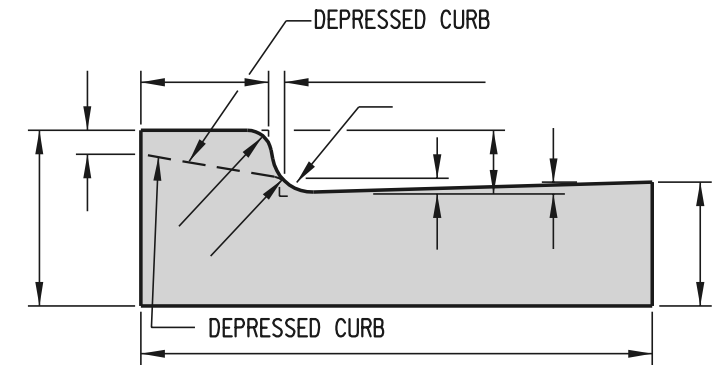

**INTEGRAL P.C.C. CURB AND GUTTER**  
TYPE 4

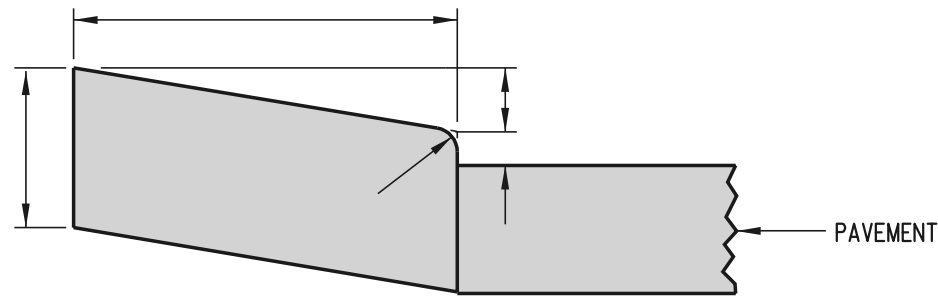

**P.C.C. CURB**  
TYPE 2

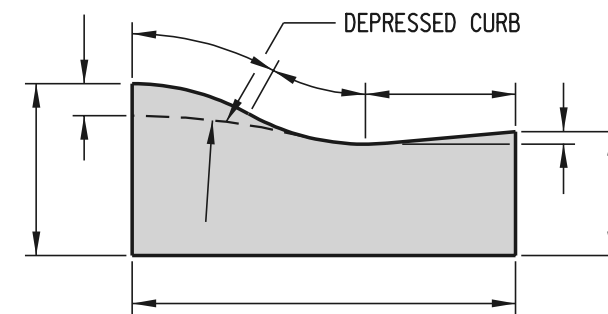

**INTEGRAL P.C.C. CURB AND GUTTER**  
TYPE 2

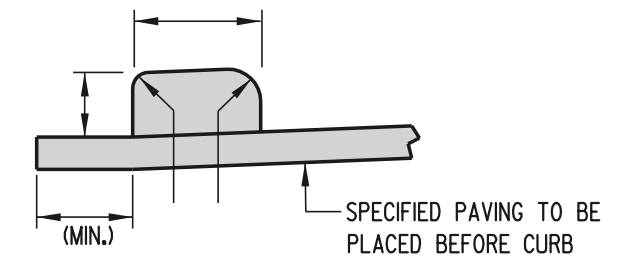

**HOT-MIX, HOT LAID BITUMINOUS**  
**CONCRETE CURB**

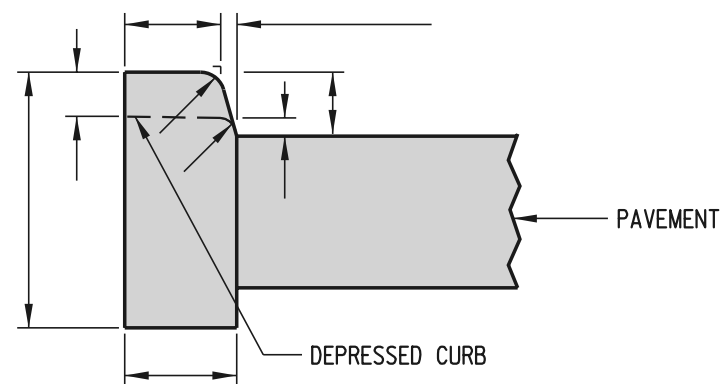

**P.C.C. CURB**  
TYPE 3

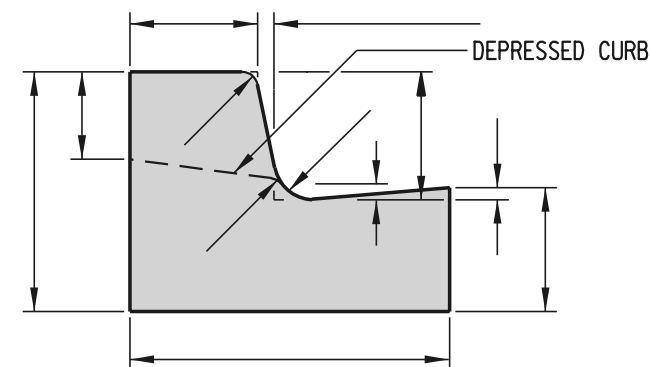

**INTEGRAL P.C.C. CURB AND GUTTER**  
TYPE 3

**NOTES:** 1. WHEN P.C.C. CURB OR INTEGRAL P.C.C. CURB AND GUTTER IS PLACED ADJACENT TO PORTLAND CEMENT CONCRETE PAVEMENT AND THERE IS A SEPARATION, USE APPROVED JOINT FILLER. TO BE PAID UNDER RESPECTIVE CURB AND GUTTER ITEM.

2. DEPRESS CURB AT DRIVEWAYS.



**DELAWARE**  
**DEPARTMENT OF TRANSPORTATION**

**P.C.C. CURB, P.C.C. CURB & GUTTER, AND HOT-MIX CURB**

**STANDARD NO.**

**C-1 (99)**

**SHT.**

**1**

**OF**

**1**

**APPROVED**

CHIEF ENGINEER

DATE

**RECOMMENDED**

DESIGN ENGINEER

DATE