



2019 Delaware Bridge Design Competition 7th – 8th Grade Guidelines

Important Dates

Team applications due: January 9, 2019

Material kit shipped: February 8, 2019

Proposal due: April 17, 2019

Competition: May 1, 2019

1. **Objective:** The objective of the Delaware Bridge Design Competition is to design and build a model truss bridge that will be tested for a strength-to-weight ratio using balsa wood. Student teams from across the state of Delaware will compete against one another, with grade levels ranging from 7th to 8th. Interested teams should fill out the application form provided on the DeIDOT Bridge Design Competition website and submit it prior to the deadline of December 7, 2018. A Challenge Entry Kit will be provided to each team to begin their project. Only materials included in the kit supplied can be used in the construction of the bridge. The material kit will be shipped by January 4, 2019. The competition objectives are for students to:
 - a) Design a **Balsa Wood Truss Bridge Model** (Specifications in section 5 of this guideline) using the least amount of materials to support the desired load.
 - b) Effectively communicate their analysis and design processes through a report portfolio. Report should include design drawings using Bentley PowerDraft CAD software.
 - c) Give an oral presentation on the final design.

Each bridge will be checked for design according to the rules. The bridges will be weighed and strength tested during the competition to calculate strength-to-weight ratio.

2. **Eligibility:** Students eligible range from 7th – 8th grade and should attend a school located in Delaware. A team must consist of three (3) members.
3. **The Challenge:** An engineer's job is to not only design a safe bridge to carry required loads, but also to make sure that it is cost effective (least amount of materials used to achieve the desired load). To simulate this process, teams will use the following strength-to-weight ratio calculation to develop a bridge that carries a high load capacity relative to the bridge weight. Strength to weight ratio is determined by dividing the maximum load carried by the weight of bridge.

Example: Assume a team constructs a bridge with the following characteristics

- Maximum load = 120 pounds (lb.)
- Unit conversion: 1 pound = 454 grams (g)
 $(120\text{lb.} \times 454\text{g/lb.}) = 54,480\text{g}$
- Bridge weight = 20g
- Ratio : $\frac{54,480\text{ g}}{20\text{ g}} = 2,724$

4. **Materials:** Provided in kit

- a) Balsa Wood
- b) Ruler
- c) Long Pins
- d) Drafting Paper
- e) S-Hook
- f) U-Bolt Bracket
- g) Wax Paper
- h) Model Smart 3D Software
- i) Wood Glue
- j) Painter's Bucket
- k) Measuring Cup
- l) Safety Cutters
- m) Safety Manual
- n) Bridge Builder CD
- o) Teacher's Guide CD
- p) MicroStation V8i Software

5. **Bridge Specifications:** Students will design and build a model truss bridge based on the following specifications.

- a) The materials provided in the kit are the ONLY materials to be used when building the bridge structure. Any modifications to the structural properties of the balsa wood or using different glue than provided will result in judges recording zero (0) weight held.
- b) The instrument used for testing will be the Pitsco Structures Testing Instrument as seen below.
- c) Lamination shall be permitted one layer thick as shown in the picture below.
- d) Connections can be butt joints, miter joints, or notched joints. Lap splices are permitted, but no greater than 1/4 of an inch.
- e) End to end, the length of the entire bridge must be 14 inches.
- f) Maximum width of the bridge shall be no more than 4.5 inches.
- g) A block of wood that is 12 inches long by 2 inches wide by 1 inch high must be able to be pushed across the bridge deck (a solid bridge deck is not required).
- h) Tester supports will be placed at 14 inches on center. Support dimensions are shown below.
- i) The bridge shall only touch the top of the Pitsco Tester Supports as seen in the diagram below. If the bridge touches any other part of the tester body, judges will record zero (0) weight held.
- j) The bridge deck must have a 3/4 inch hole in mid-span to allow a 5/8 inch testing rod to pass through and attach to a 12 inch block of wood for strength testing as seen in the picture and the diagram below. The rod must be able to pass through the full height of the bridge. Diagrams do not represent the required design and shall only be used for dimension reference.

- k) The bridge must meet the truss bridge definition: A truss bridge is a bridge whose load-bearing superstructure is composed of a truss. A truss is a structure of connected elements that form triangular units. The connected elements (typically straight) may be stressed from tension, compression, or sometimes both in response to dynamic loads.

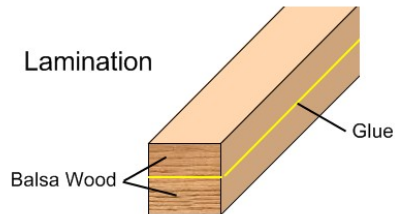

Figure 1. Lamination

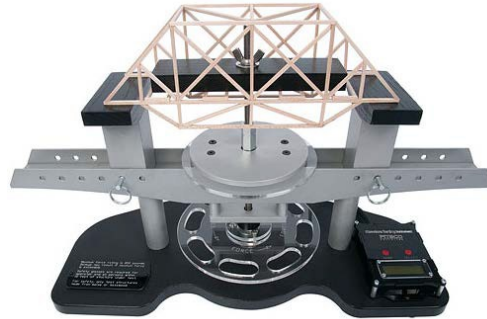

Figure 2. Pitsco Structures Testing Instrument

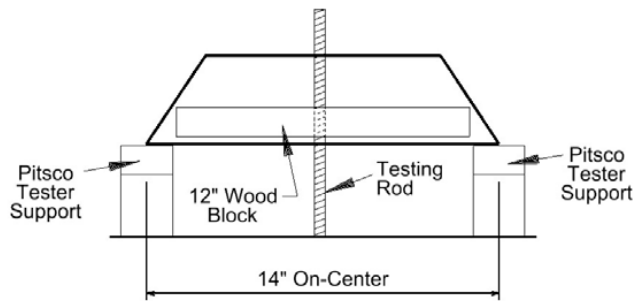

Figure 3. Tester Detail

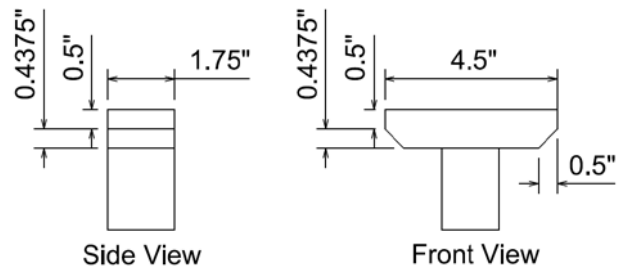

Figure 4. Support Detail

PERFORMANCE (50% of the total score) – Achievement of performance goals and stability of construction. Bridges will be weighed and then tested on the Pitsco structural tester. Results will be used to calculate strength-to-weight ratio. Any bridge not meeting the specifications in section 5 will result in judges recording zero (0) weight held. Bridge performance will be given a maximum of 100 points:

- 50 points for following bridge specifications in section 5.
- 50 points based on strength-to-weight ratio. Scores on the strength-to-weight ratio will be based on the following equation: $(\text{Ratio}_i / \text{Ratio}_{\text{Highest}}) * (50 \text{ points})$
 - Ratio_i = The strength-to-weight ratio of the team being judged
 - $\text{Ratio}_{\text{Highest}}$ = The highest strength-to-weight ratio recorded amongst all teams

Example:

Team 1 – Strength-to-Weight Ratio = 3000; $(3000 / 3000) * (50) = 50$ Points

Team 2 – Strength-to-Weight Ratio = 2000; $(2000 / 3000) * (50) = 33.33$ Points

Team 3 – Strength-to-Weight Ratio = 1000; $(1000 / 3000) * (50) = 16.67$ Points

6. **Proposal Specifications:** The information below gives an indication of what the judges are looking for in each section.

a) **Proposal Format:** The written proposal should be typed, double-spaced using size 12 Times New Roman font on 8.5 x 11 paper with all pages numbered, and 1 inch margins all around. Sections **must** be in order of the outline below.

- I. **Title Page** – Include name of competition, type of bridge, team name, team logo (each team must have a unique logo), name of the school or organization, names of students, name of teacher or advisor.
- II. **Table of Contents.**
- III. **Summary (abstract)** – Clearly and concisely stated. (At least ½ page, no more than one page).
- IV. **Introduction** – Indicate the team name, team members as well as the background of each member
- V. **Body** – The main part of the report.
 - i. Explain the scientific principles behind your design.
 - ii. Describe the challenges you encountered in designing your bridge.
 - iii. Include Data Tables, Graphic Representation of Tests, and supporting Calculations page.
 - iv. Include scaled drawings of preliminary and final bridge designs.
 - v. Include at least five (5) pictures of team work during bridge design and construction, along with a picture of the constructed bridge (prototype or final).
 - vi. Explain how you tested your design, and the improvements this led you to make.
 - vii. Describe the challenges that you encountered in building your bridge and how you solved these problems. Include safety precautions, building methods, etc.
- VI. **Conclusions** – How successful is your project? What did you learn by participating?
- VII. **Acknowledgments** – List the names of the adults who assisted you in the project with a brief description of what they did. Include a certification, signed by all student team members and adults assisting, stating that: “We hereby certify that the majority of the ideas, design, and work was originated and performed by the students, with limited assistance by adults, as described above.”
- VIII. **Bibliography** – List all references used, including Internet, books and magazines.
- IX. **Appendices**
 - i. **Scheduling and Accomplishments:** Show on a time line, or similar method, how you scheduled your project. Include brief records of meetings, telling how you managed the scheduled.
 - ii. **Daily Journal:** Progress reports of day-to-day work on the project, including date, performance and comments from each team member.

- iii. **Design Software:** Include screen-shots of Model Smart 3-D software showing truss model and max forces experienced by member results.
- iv. **Photos:** Provide a max of three photos of the bridge model under construction and one photo of the bridge completed.

b) **Timeliness:** Proposals received after the deadline will not be accepted.

PROPOSAL (20% of the total score) – Proposal reports will be evaluated on formatting, presentation, and design and construction. Reports should be well thought out and provide substantial information on the design process. See page 9 for scoring assessment and a helpful guide to follow while formulating the proposal.

After completing the project, each team is required to submit two (2) proposal copies to Craig Stevens, the State Bridge Engineer for the Delaware Department of Transportation. Do not send the bridge itself, but you **must include pictures of the bridge (prototype or final)**. The proposal must be postmarked no later than March 28, 2019. All entries become the property of Delaware Department of Transportation and will not be returned. The day of the competition, teams will present a 10 minute PowerPoint presentation and structurally test their bridges against teams throughout the state to determine the winning bridge.

7. **Design Drawing Specifications:** Computer Aided Drafting (CAD) is used to convey an engineer's plan to stakeholders in order to produce safe, efficient, and cost effective projects. Bentley PowerDraft CAD is provided at no cost to all participants. Refer to the website for download instructions and how to use video tutorials. All design drawings required for the competition must be created using Bentley PowerDraft software. Judges will examine each entry to make sure it fits the specifications given in the rules. Each team's drawings must resemble their balsa wood truss bridge model entered in the competition.

Specifications

- a) Three (3) views must be provided:
 - I. Plan (top view looking down on bridge)
 - II. Section (vertical slice through center of the bridge)
 - III. Elevation (side view of bridge)
- b) Bridge dimensions and labels of each view are required
- c) Drawings must be on 8 ½" x 11" paper and displayed at the competition
- d) Each sheet must be complete with a sheet border displaying the following information:
 - I. Team name
 - II. Team member names
 - III. Date drawing was completed

DESIGN DRAWINGS (10% of the total score) – Bentley PowerDraft CAD drawings of the bridge showcases the team's use of the software. Drawings will be given a maximum of 100 points:

- a) 50 points for minimum requirements stated above
- b) 50 points for greater detail of bridge components (showing member thickness, details of joint types, detailed labeling of components, etc.)

8. **Oral Presentation:** Teams attending the 2019 DeIDOT Bridge Design Competition will present to a panel of judges comprised of various DeIDOT engineers. Each team will be expected to make a PowerPoint presentation and be able to answer questions from the panel of judges about their entry. Supporting materials may be presented to the judges.

ORAL PRESENTATION (20% of the total score) – Teams will present a 10 minute PowerPoint presentation (a deduction is assessed if over 10 minutes). A 5 minute questionnaire session will follow the presentation, where judges will ask questions pertaining to each team's project. A rubric on page 10 has been provided for the presentation as a guide.

PREPARING FOR COMPETITION

Form a team of interested students or friends. Discuss the challenges and design specifications. Teams are limited to only three (3) students. Each team must have at least one teacher or other adult to help and advise, though a single adult may be advisor to more than one team.

Study the rules. The individual challenge documents and the grading criteria will give important information, which must be followed if your team is to achieve the best results. Failure to adhere to the rules could lead to penalties, or even disqualification. If any of the information is not clear, please call for additional help.

Plan the timing of the project. Ensure that everyone in the team knows the date for submission of the written report, and recognizes that this means that all major development work should be finished before this date.

Keep records of meetings and working drawings carefully, and give members of the team responsibility for different sections of the final report.

Notes to Adults: It is extremely important that **the work on all phases of the project is to be done by the students.** Adult assistance is to be limited to:

- Mentoring
- Basic guidance of the students
- Teaching engineering, mathematical and scientific principles applicable to the project
- Guiding students in research
- Assisting in the production of the report and preparation of the drawings
- Overseeing the manufacturing stages of the project

Guidance should be in the form of asking questions, (leading questions if necessary) to promote creative thinking by the students to identify the scientific and engineering principles involved. **Encourage students to consult credible web sites and other resources** to help with the project. **Encourage students to test and improve their designs.** A good way to begin is for each student to design and/or construct a rough prototype. Test it and make improvements.

2019 Delaware Bridge Design Competition Schedule

- 1) Applications due **January 9, 2019**.
- 2) Kits will be shipped to teams by **February 8, 2019**.
Packets will include:
 - Balsa Wood
 - Wood Glue
 - Information packet
- 3) Proposals are due **April 17, 2019** (do not include the Bridge).
- 4) Competition will be held at Polytech Adult Education Center on **May 1, 2019**.
- 5) Award ceremony **May 1, 2019**.

Proposal Scoring
2019 Delaware Bridge Design Competition

Proposal Format

- | | | | |
|---|------------|--------------|----|
| <input type="checkbox"/> Typed | (1 point) | | |
| <input type="checkbox"/> Double Spaced | (1 point) | | |
| <input type="checkbox"/> 12 Point Font (Arial or Times New Roman) | (1 point) | | |
| <input type="checkbox"/> All pages on 8.5 x 11 paper | (1 point) | | |
| <input type="checkbox"/> Information is in the proper order | (1 point) | | |
| <input type="checkbox"/> All pages are numbered | (1 point) | | |
| <input type="checkbox"/> Style and presentation | (3 points) | | |
| <input type="checkbox"/> Mechanics | (3 points) | | |
| <input type="checkbox"/> Visuals | (3 points) | Score _____/ | 15 |
| points | | | |

Proposal Presentation

- | | | | |
|---|-------------|--------------|-----|
| <input type="checkbox"/> Title page | (1 point) | | |
| <input type="checkbox"/> Table of Contents | (1 point) | | |
| <input type="checkbox"/> Summary (no more than 2 pages) | (5 points) | | |
| <input type="checkbox"/> Introduction | (1 points) | | |
| <input type="checkbox"/> Body | | | |
| <input type="checkbox"/> Sections identified | (1 points) | | |
| <input type="checkbox"/> Scientific principles of the design | (5 points) | | |
| <input type="checkbox"/> Design challenges | (5 points) | | |
| <input type="checkbox"/> Tables, Graphs, Calculations | (10 points) | | |
| <input type="checkbox"/> Detailed scaled drawings | (15 points) | | |
| <input type="checkbox"/> Photos during and after construction | (10 points) | | |
| <input type="checkbox"/> Testing and improvements | (5 points) | | |
| <input type="checkbox"/> Solving challenges | (5 points) | | |
| <input type="checkbox"/> Conclusion | | | |
| <input type="checkbox"/> Recommendations | (3 points) | | |
| <input type="checkbox"/> Success of the project | (5 points) | | |
| <input type="checkbox"/> What was learned by taking part | (4 points) | | |
| <input type="checkbox"/> Acknowledgements | | | |
| <input type="checkbox"/> Adults involved | (1 points) | | |
| <input type="checkbox"/> Description of what the adults did | (1 points) | | |
| <input type="checkbox"/> Certification and signatures | (1 points) | | |
| <input type="checkbox"/> Bibliography | (1 points) | | |
| <input type="checkbox"/> Appendices | | | |
| <input type="checkbox"/> Schedule on a timeline or similar | (5 points) | | |
| <input type="checkbox"/> Daily Journals (must be legible) | (20 points) | Score _____/ | 105 |
| Points | | | |

Design and Construction

- | | | | |
|---|-------------|--------------|----|
| <input type="checkbox"/> Achievement of design specifications | (30 points) | Score _____/ | 30 |
| points | | | |

TOTAL SCORE: _____/150 Points

Oral PowerPoint Presentation

Team will present to a panel of judges comprised of engineers from DelDOT. Each team is expected to make a PowerPoint presentation and be able to answer questions for them at panel of judges at the conclusion of their presentation. Each presentation should be a maximum of 10 minutes with an additional 5 minutes allotted for question at the end. A deduction will be assessed for presentations exceeding 10 minutes. A rubric scoring rubric has been provided for the presentation as a guide to assist in preparation.

Scoring:

Each category will be judged on a scale from 1 to 20 points.

CATEGORY	20	15	10	5	0	Sub-Score
Content	Covers topic in-depth with details and examples. Subject knowledge is excellent.	Includes essential knowledge about the topic. Subject knowledge appears to be good.	Includes essential information about the topic but there are 1-2 factual errors.	Content is minimal OR there are several factual errors	Did not fulfill requirements	_____/20
Mechanics	No misspellings or grammatical errors.	Three or fewer misspellings and/or mechanical errors	Four misspellings and/or grammatical errors.	More than 4 errors in spelling or grammar.	Did not fulfill requirements	_____/20
Organization	Content is well organized using headings or bulleted lists to group related material.	Uses headings or bulleted lists to organize, but the overall organization of topics appears flawed.	Content is logically organized for the most part.	There was no clear or logical organizational structure, just lots of facts.	Did not fulfill requirements	_____/20
Presentation	Interesting well-rehearsed with smooth delivery that holds audience attention.	Relatively interesting, rehearsed with a fairly smooth delivery that usually holds audience attention.	Delivery not smooth, but able to hold audience attention most of the time.	Delivery not smooth and audience attention lost.	Did not fulfill requirements	_____/20
Attractiveness	Makes excellent use of font, color, graphics, effects, etc. to enhance the presentation.	Makes good use of font, color, graphics, effects, etc. to enhance to presentation.	Makes use of font, color, graphics, effects, etc. but occasionally these detract from the presentation content	Use of font, color, graphics, effects etc. but these often distract from the presentation content.	Did not fulfill requirements	_____/20
Total Sub-Score						_____/100
Over 10 Minutes: (-2 pts per minute)						_____
TOTAL SCORE						_____

**2019 Delaware Bridge Design Competition
Suggestions and Helpful Hints**

1. Students should be prepared for questions at the end of the presentation. These questions may be concentrated in the following topics. However, note that the judges are free to ask any question about any topic. Therefore, each team should be prepared.
 - a) Choice of design
 - b) Civil engineering careers related to bridges
 - c) Safety
 - d) Impacts of bridges
 - e) Lessons learned
2. Stay organized and keep track of time limits.
3. If you have a question, ASK. You can contact:
 - a) Nicholas Dean at nicholas.dean@state.de.us
 - b) Scott Walls at scott.walls@state.de.us
4. Contact your DOT engineer mentors. They will answer many of your questions.
5. Check out other bridges in your area or around the world.
6. Include detailed information in the team portfolio. Remember, your portfolio is what determines if your team is selected to come to national competition.
7. Research.