

**Delaware Department of Transportation
Division of Transportation Solutions
Design Guidance Memorandum**

Memorandum Number 1-18 Revised

- | | | |
|-----------------------|----------------------------|----------------------------------|
| 1. Road Design Manual | 2. Bridge Design Manual | 3. Utilities Design Manual |
| 4. Real Estate Manual | 5. Standard Specifications | 6. Standard Construction Details |

Title: Continuous Centerline and Longitudinal Edgeline Rumble Strips Effective date: May 16, 2011

Sections to Implement:

- | | | |
|---|---|---|
| <input checked="" type="checkbox"/> Project Development | <input checked="" type="checkbox"/> Planning | <input type="checkbox"/> DTC |
| <input checked="" type="checkbox"/> Bridge | <input checked="" type="checkbox"/> Quality | <input checked="" type="checkbox"/> Traffic |
| <input checked="" type="checkbox"/> Team Support | <input checked="" type="checkbox"/> Maintenance &
Operations | <input type="checkbox"/> Other _____ |
| <input checked="" type="checkbox"/> Utilities | | |

I. Purpose

To define when and where continuous centerline and longitudinal edgeline rumble strips should be applied within the state highway system. (See Figures 1 through 5.)

II. Design Guidance

The purpose of continuous centerline or longitudinal edgeline rumble strips is to enhance safety by mitigating the potential of crossover or road departure crashes. Rumble strips are intended to alert drivers by creating an audible (noise) and tactile (rumble or vibratory) warning sensation to indicate to the driver that the vehicle is leaving the traveled way (traffic lane) and that a steering correction may be required. Before and after crash studies have indicated that both crossover and roadway departure crashes may be reduced significantly by the use of rumble strips.

The intent of the rumble strip is to gain the attention of a driver. Naturally, the byproduct of this measure is noise. In isolated areas this is usually not a problem. However, when installed in a suburban or urban area, the noise from rumble strips may impact nearby residents. It is highly recommended to consider the noise implications of rumble strips if they are going to be located in a populated area. If there is any concern that noise could be an issue, consult Engineering Support and Public Relations to determine if noise will be a concern.

Continuous milled rumble strips should be considered and installed per the following guidelines and details.

A. Continuous Longitudinal Edgeline Rumble Strips

1. Interstates, Freeways and Expressways (Limited Access Facilities)
 - a. Continuous longitudinal edgeline rumble strips should be installed adjacent to the inside and outside shoulders of all Interstates, freeways and expressways, regardless of crash history.
 - b. Continuous longitudinal edgeline rumble strips should be installed on both the inside and outside shoulders of all interchange ramps regardless of crash history.
 - c. The continuous longitudinal edgeline rumble strips should be in accordance with Figures 1A, 1B and 1C.
 - d. Rumble strips 0.375" in depth should be installed on bridge decks longer than 200 feet.

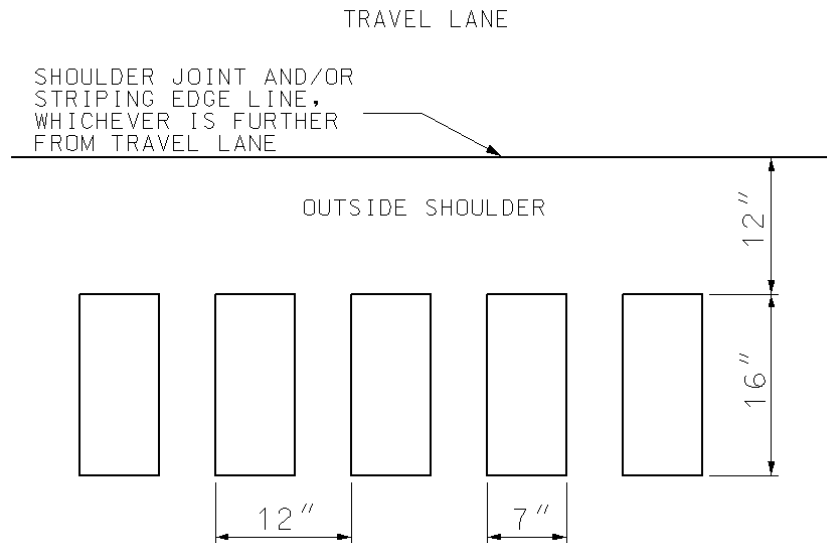

Figure 1A - Continuous Longitudinal Edgeline Rumble Strip Detail

NOT TO SCALE

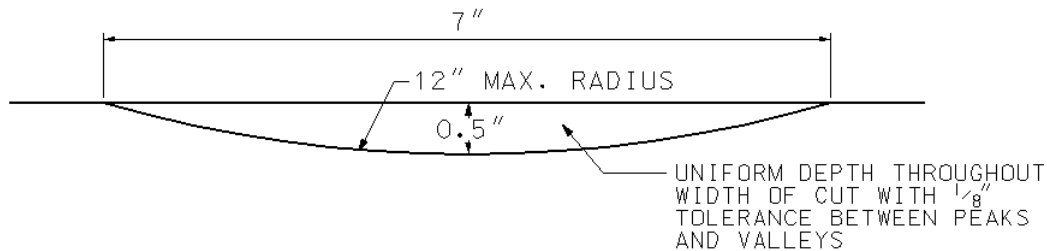

Figure 1B - Rumble Strip Section - Interstates, Freeways And Expressways

NOT TO SCALE

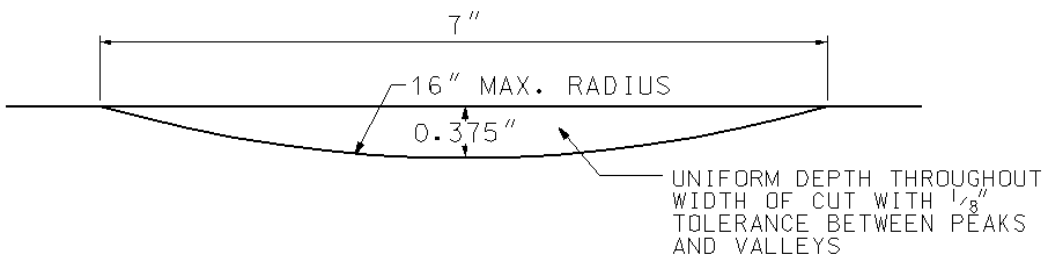

Figure 1C - Rumble Strip Section - Bridge Decks

NOT TO SCALE

2. Multilane Conventional Roadways

- a. Bicycle-Friendly Edgeline Rumble Strips should be installed adjacent to the outside shoulders of all multilane conventional roadways. Continuous edgeline rumble strips should be installed adjacent to the inside shoulders of all multilane conventional roadways.
- b. Bicycle-Friendly Edgeline Rumble Strips should be installed as shown in Figures 2A, 2B and 2C.
- c. Rumble strips 0.375" in depth should be installed on bridge decks longer than 200 feet.

- d. Rumble strips are to be broken for all intersections and driveway entrances where the edgeline pavement markings tie into the driveway entrance or the edgeline pavement markings are broken. The installation of rumble strips should be stopped 25 feet prior to the point of curvature (PC) and restarted 25 feet after the point of tangency (PT).
- e. Rumble strips should not be installed on acceleration, deceleration or bypass lanes, or two-way left turn lanes. Installation should stop 150 feet prior to the diverge point of a deceleration lane and should not commence until 150 feet downstream of the merge point for an acceleration lane.
- f. To accommodate bicyclists, a minimum effective clear shoulder width of 4 feet should be provided from the outside edge of the rumble strip groove to the outside edge of the paved shoulder (see Figure 2A), or 5 feet from the outside edge of the rumble strip groove to the front face of barrier (including curb) or guardrail. Rumble strips should be discontinued 50 feet before and started 50 feet after when adjacent to guardrail with less than 5 feet between the outside edge of the rumble strip and the face of the guardrail.
- g. If the above clear area cannot be maintained, then consider installing *Bicycle-Friendly Edgeline Rumble Stripes* within the painted edgeline. A *Rumble Stripe* is a milled rumble strip that is placed on the painted edgeline and the edgeline is repainted over the top of the milled rumble strip. (See Figure 3.) If no shoulder exists, the installation of *Rumble Stripes* should be considered. *Rumble Stripes* shall meet the longitudinal design of Bicycle-Friendly rumble strips.
- h. The Bicycle-Friendly Edgeline Rumble Strip pattern shall consist of 40-foot long segments of rumble strips with 12-foot segments of no rumble strips.

3. Two-Lane Conventional Roadways

- a. Bicycle-Friendly Edgeline Rumble Strips should be installed on all rural two-lane roadways with a minimum of 11 foot lanes, 5 foot shoulders, and a posted speed limit or 85th percentile speed of 40 miles per hour or higher.
- b. Bicycle-Friendly Edgeline Rumble Strips should be considered for installation on all other rural two-lane roadways if an engineering study determines that road departure crash rates along the section of roadway exceed statewide or national averages for similarly classified roadways and if rumble strips are a viable crash reduction countermeasure for the particular roadway.
- c. Bicycle-Friendly Edgeline Rumble Strips should be installed in accordance with the details provided in Figures 2A, 2B and 2C.
- d. Rumble strips 0.375" in depth should be installed on bridge decks longer than 200 feet.
- e. Rumble strips are to be broken for all intersections and driveway entrances where the shoulder edgeline pavement markings tie into the driveway entrance or where the edgeline pavement markings are broken. The installation of rumble strips should be stopped 25 feet prior to the turn radius PC and restarted 25 feet after the turn radius PT.
- f. Rumble strips should not be installed on acceleration, deceleration or bypass lanes, or two-way left turn lanes. Installation should stop 150 feet prior to the diverge point of a deceleration lane and should not commence until 150 feet downstream of the merge point for an acceleration lane.

- g. Generally, continuous or bicycle-friendly longitudinal edgeline rumble strips should not be applied on the shoulders of roadways within urban areas. In urban areas, the designer should consult with Engineering Support and Public Relations to determine if noise will be a concern. Urban areas are depicted on the DelDOT Functional Classification Maps by an Urbanized Area Boundary or Small Urban Boundary.
- h. To accommodate bicyclists, a minimum effective clear shoulder width of 4 feet should be provided from the outside edge of the rumble strip groove to the outside edge of the paved shoulder (see Figure 2A), or 5 feet from the outside edge of the rumble strip groove to the front face of barrier (including curb) or guardrail. Rumble strips should be discontinued 50 feet before and started 50 feet after when adjacent to guardrail where there is less than 5 feet between the outside edge of the rumble strip and the face of the guardrail.
- i. If the above clear area cannot be maintained, then consider installing *Bicycle-Friendly Edgeline Rumble Stripes* within the painted edgeline. A *Rumble Stripe* is a milled rumble strip that is placed on the painted edgeline and the edgeline is repainted over the top of the milled rumble strip (see Figure 3.) If no shoulder exists, the installation of *Rumble Stripes* should be considered. *Rumble Stripes* shall meet the longitudinal design of Bicycle-Friendly rumble strips.
- j. The Bicycle-Friendly Edgeline Rumble Strip pattern shall consist of 40-foot long segments of rumble strips with 12-foot segments of no rumble strips.

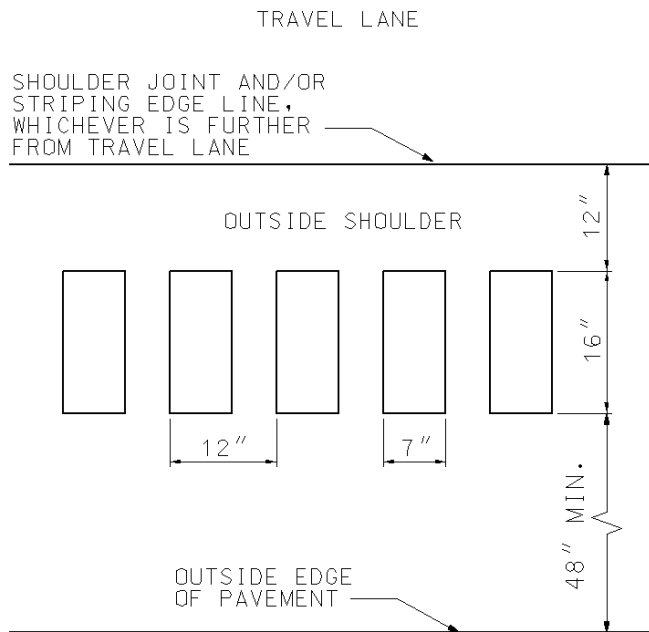

Figure 2A - Bicycle-Friendly Edgeline Rumble Strip Detail

NOT TO SCALE

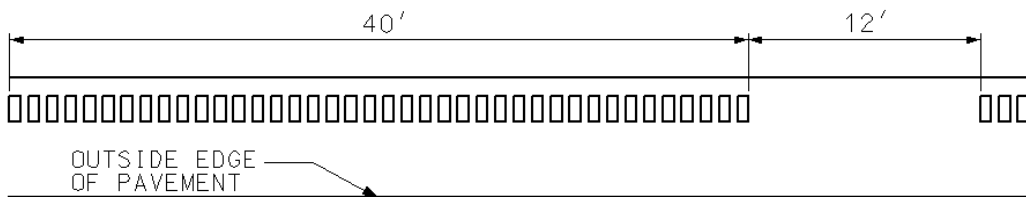

Figure 2B - Bicycle-Friendly Edgeline Rumble Strip Layout

NOT TO SCALE

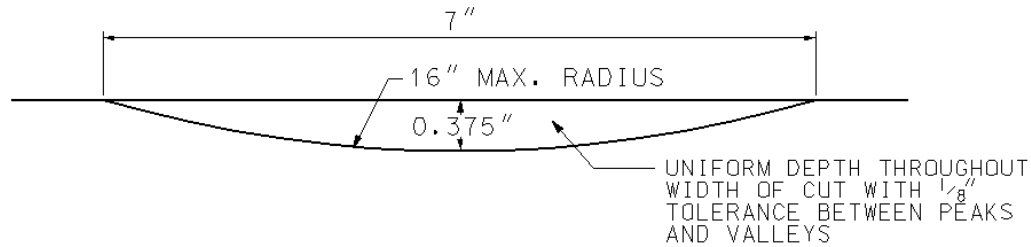
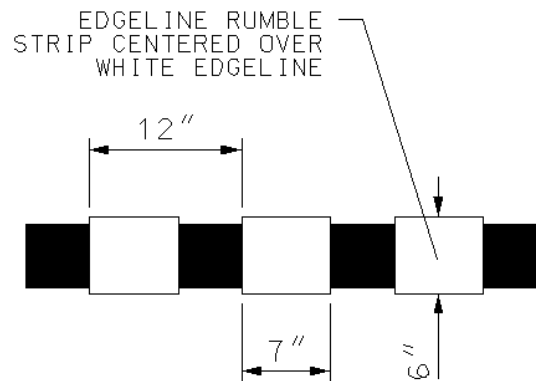

Figure 2C - Bicycle-Friendly Rumble Strip Section

NOT TO SCALE



(NOTE: PORTIONS OF PAVEMENT MARKINGS REMOVED FOR CLARITY.)

Figure 3 - Bicycle-Friendly Edgeline Rumble Stripe Detail

NOT TO SCALE

B. Continuous Centerline Rumble Strips

1. Continuous centerline rumble strips should be considered on all conventional two-lane and undivided multilane roadways where an engineering study determines that crossover or head-on crash rates along the section of roadway exceed statewide or national averages for similarly classified roadways and if rumble strips are a viable crash reduction countermeasure. The study should be reviewed and approved by the Chief Traffic Engineer or designee.
2. The installation of continuous centerline rumble strips shall be in accordance with Figure 4.
3. Continuous centerline rumble strips should start and end following the centerline striping. Where the centerline leads into a raised concrete island, the rumble strips should be discontinued within 10 feet of the nose of the island. Where the centerline splits to create, for example, a turn lane, the rumble strips should be placed adjacent to both yellow edgelines.
4. On roads with recessed pavement markers (RPMs), centerline rumble strips should begin one foot downstream of the RPM housing and terminate one foot upstream of the RPM housing, as shown in Figure 5.

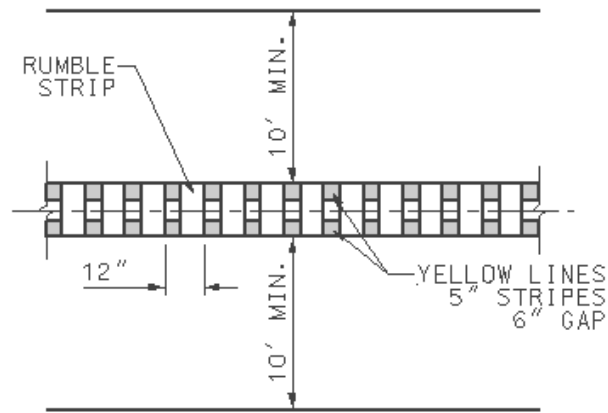

(NOTE: PORTIONS OF PAVEMENT MARKINGS REMOVED FOR CLARITY.)

Figure 4 - Continuous Centerline Rumble Strip Detail

NOT TO SCALE

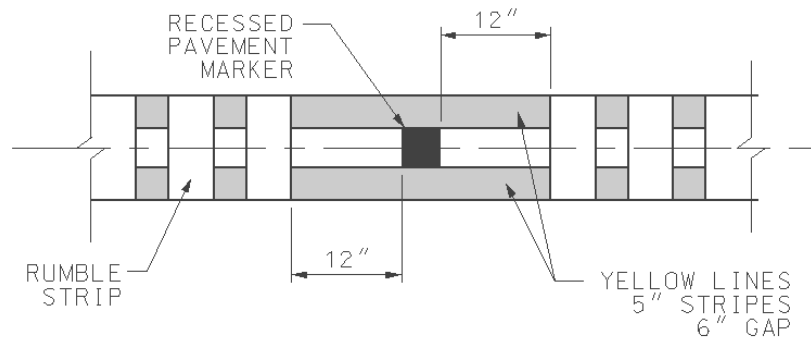

(NOTE: PORTIONS OF PAVEMENT MARKINGS REMOVED FOR CLARITY.)

Figure 5 - Continuous Centerline Rumble Strip With Recessed Pavement Marker Detail

NOT TO SCALE

C. Other Considerations

The composition of the new pavement section and the thickness, condition, and type of existing pavement needs to be determined and evaluated prior to the application of milled rumble strips. The installation of milled rumble strips on pavement that is of questionable thickness, condition, or type (e.g. hot-mix over P.C.C. pavement) needs to be evaluated to ensure that the installation of the rumble strip will be possible without adverse impact to the pavement or the performance of the strip. The designer should contact the Materials and Research Section for existing pavement cores. If no core data is available, pavement cores should be requested from the Materials and Research Section and evaluated before further design.

For construction projects on roadways with existing rumble strips, the rumble strips should be eliminated if the temporary traffic control plans require traffic to be shifted onto the shoulder or across the centerline. Longitudinal rumble strips should be relocated when traffic patterns are changed within long-term stationary work zones. The use of milled rumble strips within the temporary traffic control plan should be reviewed by the Traffic Safety Section.

This guidance does not account for all possible applications (e.g., rural gore areas). Therefore, it may be necessary for the designer to develop special plans or details for the application of milled or alternative longitudinal rumble strip treatments. All such plans and details should be submitted to the Traffic Safety Section for review prior to their use on a project. This includes the use of centerline rumble strips on two-way highways where additional factors such as lane width, total roadway width, etc. should be considered.

III. Justification

To improve safety by alerting inattentive drivers through vibration and sound with continuous centerline and/or longitudinal edgeline rumble strips that their vehicles have left the travel lane. This safety countermeasure has shown proven results and is a recommendation of the State of Delaware Strategic Highway Safety Plan. A 2003 Federal Highway Administration study found the benefit/cost ratio of the rumble strips installed on I-95 south of Wilmington in 1998 was approximately 7:1; the unit cost for the rumble strips on this project was \$7.92 per foot. The price of rumble strips has dropped significantly since this installation, e.g., only 24 cents per foot in 2003 for an SR 1 project. If this had been the unit price for the I-95 project, the benefit/cost ratio would have been 212:1. A benefit to cost ratio for an installation of centerline rumble strips along US 301 was determined to be 110:1.

Prepared by: Traffic Section

Revised Date: March 22, 2011

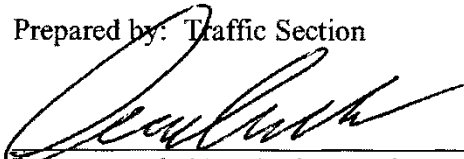
Recommended by: Assistant Director – Traffic

4/21/11
Date

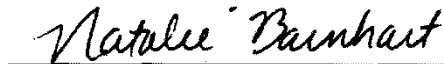
Approved: Chief Engineer

5/4/11
Date

Distribution:
Transportation Solutions Assistant Directors
Maintenance & Operations District Engineers
Transportation Solutions
Planning
Consultants
DelDOT Internet Site