



IV. TRAFFIC SIGNALS

A. Traffic Signal Justification Study

Prior to initiating the design for the installation, modification, or removal of a traffic signal, it is necessary to conduct an engineering study to establish its purpose and need. The purpose of the study is to evaluate all intersection configurations (with major consideration given to roundabouts), the applicability of a traffic control signal for a given location, evaluate less-restrictive intersection treatments, define the operational requirements for the intersection, and identify key features/ constraints which will influence the design of the selected treatment. This chapter of the Traffic Design Manual defines the required elements of a Traffic Signal Justification Study. A sample study is included as part of this Manual in **Appendix G**.

The process and requirements for a signal modification study may be reduced from that of a new signal study. However, at a minimum, data related to the existing signal should be collected, recent traffic count data should be used, and capacity analysis should be performed. Other studies and data may also be required for a signal modification project on a case-by-case basis depending on the scope of the project, the project budget, and the project schedule.

1. Study Initiation

A Traffic Signal Justification Study is often initiated by DelDOT's Traffic Studies Group following a request for signalization. The request may be from a citizen, elected official, or developer, either due to a desire for signalization or as a requirement associated with the approval of a traffic impact study (TIS). For proposed signals associated with Capital Projects, DelDOT's Project Development Group will typically coordinate with DelDOT's Studies Group or on-site consultants to initiate the study. For proposed signals requested by a developer, the developer is responsible for developing a traffic impact study (TIS) or traffic operational analysis (TOA) according to the guidelines in the Development Coordination Manual, pending review from the DelDOT Studies Group.

2. Traffic Data Collection

Once a Traffic Signal Justification Study has been initiated, the first step is to gather relevant traffic data. An accurate Traffic Signal Justification Study depends on the quality of the traffic data collected, and a thorough understanding of the existing conditions of the intersection. At a minimum, intersection turning movement counts must be collected or obtained, historical crash data should be obtained, a site visit should be conducted, and sight distances should be documented. Additionally, delay studies, queuing studies, spot speed studies, and gap studies may also be required, depending on the specific characteristics of the



intersection. Prior to in-field data collection, the “State of Delaware Highway Right-of-way Use Agreement for Temporary Data Collection Devices” form should be completed by the engineer of record to allow for the deployment of data collection devices. Prior to installation in the field, the engineer shall notify the TMC of the device type and location.

An initial **Site Visit** should be conducted at the study location. The site visit should identify lane configurations, important roadway features, signing, lighting, utilities, pedestrian features, transit stops, adjacent signalized intersections, and information on the surrounding land uses. The site visit should also include written observations of traffic flow during peak and off-peak periods to gain a thorough understanding of the operational characteristics of the intersection and to identify potential safety hazards. Photographs and sketches of the intersection may be useful in documenting the findings of the site visit. During the site visit, **Intersection Sight Distance (ISD)** should be determined. Guidance on calculating intersection sight distance is provided in the AASHTO reference [A Policy on Geometric Design of Highways and Streets](#).

For signal modification projects, existing signal timing and phasing data should also be collected during the site visit. To account for variability in cycle length and phase duration associated with actuated control, multiple signal cycles (typically between 5 and 10) should be observed in the field and compared to timing data obtained from the TMC.

Intersection Turning Movement Counts are a type of directional traffic count typically performed at roadway intersections. These counts quantify the volume of traffic for each movement through the intersection. These counts are typically conducted manually. Since data throughout the day is required to conduct a signal warrant analysis, 12- or 13-hour counts would be ideal. However, in most cases, an 8-hour count covering the morning, mid-day, and evening peak hours are acceptable. For long-term planning projects, counts collected during the AM and PM peak periods (a minimum of two hours of data during each peak period) may be sufficient, since off-peak trip generation is typically not performed. The volume of pedestrians and bicycles crossing each leg of the intersection should be collected during all intersection turning movement counts, even for locations without marked crosswalks. Counts should be conducted for signal modification projects, as well as new signal projects.

There are several other types of traffic volume counts that may also be useful in preparing a Traffic Signal Justification Study. **Total Volume Counts** tabulate the number of vehicles passing a single point along the roadway. These counts can either be bi-directional (total volume in both directions) or directional (total volume in one direction). These counts can be used to estimate Average Daily Traffic (ADT) volumes on each of the intersection approach



legs, and they can also provide useful information regarding the variation in traffic throughout the day. **Classification Counts** identify the number and type of vehicles (passenger cars, buses, single-unit trucks, tractor-trailers) using the roadway network. Classification Counts should be conducted if truck traffic is cited as one of the key contributing factors for the need for signalization, or if trucks represent a significant portion of the traffic at any of the key movements at the intersection. Total Volume Counts and Classification Counts are typically conducted using automatic traffic count devices (typically consisting of pneumatic tubes stretched across the road) and are typically collected for a minimum of 24 to 48 hours.

It is advisable to check for any available traffic data before performing new counts. In general, traffic data should be 2 years old or newer when used in Traffic Signal Justification Studies. All project-specific traffic data should be compared with information provided in DelDOT's Traffic Summary Report to verify the reasonableness of the data. Comparisons should be made with peak hour and/or daily traffic data, as appropriate.

Historical **Crash data** for the intersection for the most recent 3-year period available should be obtained. The crash data should be summarized and evaluated to identify crashes of types that are susceptible to correction by the installation of a traffic control signal or other alternative intersection treatment. Obtaining the individual police reports, in addition to the summary statistics, may provide a better understanding of crash trends.

Crash summaries for applicable projects can be requested through the Statistical Information Supervisor, however, access to individual crash reports is restricted to DelDOT personnel and their contracted consultants and requires the successful completion of a background check performed by the Delaware Department of Safety and Homeland Security. Contact the HSIP Manager or the Statistical Information Supervisor for more information.

There are several other types of traffic engineering studies that may be useful when preparing a Traffic Signal Justification Study depending on the site-specific characteristics of the study intersection. An **Intersection Delay Study** is used to quantify the amount of delay experienced by vehicles stopped at an intersection. A delay study can be used to calibrate intersection analysis software or to determine if an intersection approach meets specific signal warrant thresholds. While typically used to assess the delay of vehicles stopped on the minor street approaches to an intersection, Intersection Delay Studies can also be used to study the delay of left turns from a major street. A **Spot Speed Study** measures the travel speeds of vehicles at a specific location. A speed study may be used to determine 85th-percentile speeds for application in signal warrant analyses, for setting speed limits, and for setting appropriate clearance intervals in signal timing plans. A **Gap Study** is used to measure



the number and duration of available gaps in a traffic stream. A gap is the measurement of time between when the rear bumper of one vehicle and the front bumper of another vehicle pass a given location. Gap studies are useful for evaluating the need for a pedestrian signal and selecting appropriate left-turn phasing at a traffic control signal. Gap Studies may also be used to validate the assumptions used during the capacity analysis of the intersection. **Queuing Studies** are performed to determine the 95th percentile length and duration of queues for an entire approach to an intersection, or within a specific lane. Any spillback into nearby intersections, access points, rail crossings should be noted.

Additional guidance on how to conduct these types of traffic engineering studies can be found in ITE's Manual of Traffic Engineering Studies.

3. Signal Warrant Analysis

A key component of a Traffic Signal Justification Study is a Traffic Signal Warrant Analysis. Chapter 4C of the Delaware Manual on Uniform Traffic Control Devices (DE MUTCD) identifies nine (9) warrants which should be evaluated to determine if the installation of a traffic control signal may be justified at a given location. An additional evaluation based on "IA-19.3-Alternative Signal Warrant 7, Crash Experience – Delaware DOT Statewide" should also be performed.

a. Applicability

For analyses of existing conditions, at minimum, Warrants 1, 2, 3, and 7 should be examined. Actual traffic counts shall be used for determination of hours meeting a warrant's criteria. No average hourly volumes between two counted hours are acceptable for a final determination. For the analysis of future conditions or a projected opening day for proposed developments, at minimum, Warrants 2 and 3 should be examined. Projected future traffic volumes may be calculated using land use and trip generation data.

Warrants 1 and 2 contain criteria based on the major-street speed. If the major-street speed is possibly applicable, a spot speed study should be completed if the posted speed limit is 35 mph or 40 mph.

Satisfaction of Warrant 3 alone is typically only considered justification for a signal in special cases (the unusual nature of which must be documented). However, it should be examined in all cases. Special cases that match Warrant 3 are:

- 1. Office Complexes,**
- 2. Manufacturing Plants,**



3. **Industrial Complexes,**
4. **Schools** (high schools that have significant numbers of student drivers and any school with a significant number of parent drivers in carpools), or
5. **High-Occupancy Vehicle (HOV) facilities that attract or discharge large numbers of vehicles over a short time.**

Signals installed based solely on Warrant 3 must be operated under actuated control to detect the presence of vehicles on the minor side-street approaches, particularly during off-peak hours.

Warrants 1, 2, and 7 may use the higher major-street left turn volume as the minor approach and the opposing major-street through volume as the major-street volume.

The *Guidance* in Section 4C.01 of the DE MUTCD should be followed. This section also explains the inclusion or exclusion of turn lanes when determining the number of approach lanes to an intersection in a warrant analysis (see Section 4C.01, paragraphs 08, 09, and 10). Generally, if the lane configuration is such that right-turning traffic experiences relatively low amounts of delay, either due to ample gaps in traffic on the major street, or relatively few occasions when they are blocked from proceeding by through or left-turning vehicles, they should not be included in the analysis. If right-turn volumes are included in the minor street approach volume, a supplemental right-turn volume analysis should be conducted based on the methodology, including Figure 2-11, provided in *NCHRP 457, Evaluating Intersection Improvements: An Engineering Study Guide*. That document provides a quantitative means of estimating the volume of right-turning traffic that would not benefit from the provision of a signal. A supplemental analysis utilized by Alabama DOT based on the Pagones Theorem can also be applied to estimate the volume of right-turning traffic that would not benefit from the provision of a signal. Additional information regarding Alabama's methodology for right-turn volume adjustments can be found in the Alabama Department of Transportation's Traffic Signal Design Guide & Timing Manual.

All signals installed by DelDOT should be operational 24 hours per day, even at schools and churches. Special circumstances may justify a partial or time-of-day signal operation but, should only be deployed upon approval by the Chief of Traffic Engineering.

It is important to note that the satisfaction of a traffic control signal warrant or warrants shall not in itself require the installation of a traffic control signal. There are alternatives to traffic control signals that could be implemented that modify the traffic operations and user needs that initially warranted consideration of a traffic control signal. Also, the location of the potential traffic control signal should be evaluated in relation to spacing



with adjacent signals, where it falls in relation to overall planning of future signal locations or access management plans, and what impacts a traffic control signal will have on traffic progression in a coordinated traffic control signal system.

b. Timetable

The timetable for implementation of a traffic control signal that meets warrants and has been approved by the Traffic Section typically differs for each of the different project types. For Capital Projects (project type 1), the implementation of the traffic control signal may occur concurrently with the construction of the major roadway improvement. Alternatively, the intersection may be designed for future signalization but initially be opened to traffic under some form of stop control. Both opening day and design year projections should be analyzed.

Pavement and Rehabilitation Projects (project type 2) are generally not associated with new traffic signals. For Traffic Section Projects (project type 3), the results of the signal warrant analyses are generally applicable to existing conditions. Therefore, the design and construction of the traffic control signal can commence once the signal is approved by the Chief of Engineering and funding is secured for Traffic Section Projects.

The timetable for implementation of a traffic control signal for Developer / Subdivision Projects (project type 4) is more complex, particularly for developments with a phased build-out. The Traffic Impact Studies prepared by the Developer typically evaluate traffic operations for existing conditions and future build-out conditions. Therefore, the signal warrant results often do not reflect near-term conditions, but rather operations at some future year, when the entire development is constructed and fully occupied.

DelDOT will not install a traffic control signal on an existing roadway based on presumed future conditions. If a developer is requesting that a traffic control signal be installed at the year of opening of the development or at an interim phase of development, a signal warrant analysis should be provided to DelDOT for the expected traffic conditions at the time of opening. Committed (background) development trips should not be included in the opening-day traffic projections unless solid evidence can be provided that the committed development is likely to be in full operation for the opening-day time period.

If a location will not meet one or more of the DE MUTCD warrants until subsequent years after additional development occurs, a signal warrant analysis should be provided for the year in which the warrants are first met. In this case, there are several options that can be negotiated between DelDOT and the Developer for the treatment of the intersection before full signalization is justified. These options include 1) installing only the



underground utilities in the opening year to support the future installation of a signal, or 2) putting the signal design on hold until a future year. If a traffic signal is not justified when the facility opens to traffic, interim traffic movement restrictions may be required.

4. Safety Considerations Using the Highway Safety Manual

A Traffic Signal Justification Study should include an assessment of the safety implications of installing a new traffic signal, modifying an existing traffic signal, or removing an existing traffic signal. The Highway Safety Manual (HSM), published by AASHTO, offers a process for conducting quantitative safety analyses based on before and after studies at project sites. The HSM provides methodologies for predicting the expected average crash frequency for existing facilities, alternative designs at existing facilities, or proposed designs at future facilities. The HSM should be consulted to assist in performing the safety assessment.

DelDOT's preferred method for conducting the safety assessment is to use the "predictive method" from the HSM to estimate anticipated crash frequency. The predictive method (discussed in detail in Part C of the HSM) is an 18-step process involving three major components: 1) Safety Performance Functions, 2) Crash Modification Factors, and 3) Calibration Factors.

The **Safety Performance Function (SPF)** is a statistical regression model for estimating the average crash frequency for a facility type with specified base conditions. An SPF is a function of existing or forecasted traffic volumes and roadway characteristics.

Crash Modification Factor(s) (CMF) are used to account for a specific site condition(s) that differs from the SPF base conditions. When necessary, multiple CMFs may be applied to the SPF to account for all specific conditions at the site which vary from the SPF base conditions. However, the combined effect of multiple treatments could be overestimated if those treatments affect the same type of crash and the severity of those crashes. Therefore, engineering judgment must be used in order to determine the independence, or lack of independence, of the various CMFs.

A comprehensive database of available CMFs for different areas, roadways, crashes, and treatment types can be found on the CMF Clearinghouse website at www.cmfclearinghouse.org.

The **Calibration Factor (C)** allows the SPFs to be adjusted to match local conditions. If calibration factors have not been developed, the Calibration Factor is assumed to be 1.0, meaning the site does not vary from the SPF base conditions. It should be noted that at the



time of the publication of this Manual, DelDOT has not developed any state-specific Calibration Factors.

The risk in applying the CMF method is it involves only the observed crash frequency for a site that could potentially be experiencing a particularly high or low crash frequency period. Application of CMFs to historical crash data involves regression-to-the-means bias, meaning a treatment is selected based on short-term trends observed in crash frequency, which could be overestimating or underestimating the safety implications of that treatment. The predictive method, on the other hand, allows for the correction of short-term crash data and reduces the vulnerability of random variations in crash data.

The engineer should consult the DelDOT HSIP Manager for guidance on properly applying the methodologies contained in the HSM.

5. Alternative Intersection Treatments

As noted previously, the satisfaction of one or more of the signal warrants from the DE MUTCD does not necessitate the installation of a traffic signal at a study location. This section of the Traffic Design Manual describes alternative intersection treatments that should be considered as part of the Traffic Signal Justification Study, especially if there are potential safety concerns with the installation of a traffic signal (see Chapter IV-A.4).

It is important to note that a traffic control signal is not always the most-desirable intersection treatment. Every time DelDOT installs a new traffic control signal, additional capital and maintenance costs are incurred. Additionally, the installation of a traffic control signal may result in unintended negative consequences, such as disruption to traffic flow, additional delay to motorists on the major street, or increases in certain types of crashes. **Therefore, the Traffic Signal Justification Study should evaluate the feasibility of providing alternative traffic control that could achieve similar capacity and safety benefits to those provided by a traffic control signal.** Alternative treatments that may be considered include:

- Roundabouts
- Stop control (two-way, three-way, and all-way approach)
- Channelized / restricted turn movements
- Geometric improvements, such as the addition of an exclusive turn lane
- Improved signing, striping, and/or lighting
- Consolidated property access, resulting in fewer, more widely-spaced intersections
- Other innovative intersection treatments



When considering alternative treatments, the Engineer should consult the HSM to determine the expected change in crash frequency caused by the intersection modification, if the required data is available.

6. Capacity Analysis

A Traffic Signal Justification Study should include an analysis of the intersection capacity under both existing conditions and proposed future conditions.

a. Evaluation Methodologies

The methodologies outlined in the appropriate version of the Highway Capacity Manual (HCM), as selected by DeIDOT, should be used to conduct capacity analyses of the study intersection. The most recent versions of the Highway Capacity Software and other simulation software packages that utilize the HCM methodology are typically considered acceptable tools for conducting capacity analyses. The use of a Microsimulation tool to supplement the HCM analysis may also be desirable for the analysis of closely-spaced intersections and intersections within a corridor having coordinated signal timings.

DeIDOT also requires that all signalized intersections be evaluated using the Critical Movement Summation (CMS) methodology. Guidelines for conducting a CMS analysis are included in this manual in **Appendix I**.

b. Measures of Effectiveness

A Traffic Signal Justification Study should clearly document the projected change in operations at the study intersection due to the proposed improvements based on standard measures of effectiveness (MOEs).

Level of Service (LOS), as defined in the Highway Capacity Manual, is the standard measure of effectiveness to be used in evaluating proposed intersection improvements. For unsignalized and signalized intersections, LOS is based on the average delay per vehicle at the intersection.

Other MOEs may also be used to supplement LOS results, including 95th percentile queue lengths, volume-to-capacity ratios, and overall system delay. Additionally, the study should identify the potential for queue spillback into adjacent intersections or railroad crossings, or the potential blockage of nearby access points. Queue spillback from turn bays into the mainline should also be identified. Network bandwidth using time and space diagrams may also be reviewed to identify the impacts of adding a signal to a signalized corridor.



Operations should be analyzed for existing and future (opening day, if applicable, and full build-out) conditions with and without a signal, and with any alternate form of intersection control. If the installation of a traffic control signal is recommended, a clear improvement in operations should be demonstrated and the disadvantages of less-restrictive traffic control should be documented.

c. Signal Timing / Phasing

The Traffic Signal Justification Study should identify an appropriate preliminary timing and phasing plan for the proposed traffic control signal, which should also be used when conducting capacity analysis for the study. If the intersection is located within an existing signalized corridor, the existing signal cycle length should be used. The selected timing and phasing plan should use appropriate clearance intervals and consider the potential advantages and disadvantages of various phasing options, such as lead/lag phasing and split phasing. The timing plan should also consider coordination with adjacent signals (if needed), the anticipated type of left-turn treatment (permissive, exclusive-permissive, exclusive-only), and if pedestrian crosswalks and signals are included, the pedestrian walk and clearance timings. Refer to Section IV-E of this Manual for additional detail regarding signal timing and phasing.

7. Documentation of Results

The findings of the Traffic Signal Study should be documented in a brief report, as outlined below. A sample report can be found in **Appendix G**. If the Signal Study recommends the installation of a signal, a Signal Design / Modification Request Form (See **Appendix J**) should be initiated to advance the project to the design phase.

a. Technical Memo / Presentation

The report summarizing the Traffic Signal Study should be thorough, yet concise, and include the following elements:

Problem Identification: The technical memo or presentation should include a clear statement of the reason the Traffic Signal Justification Study was initiated, including the source of the request.

Summary of Existing Site Conditions: The technical memo or presentation should briefly summarize the number of approach lanes for each leg of the intersection, the lane configuration at the intersection, the location and length of exclusive turn lanes (storage and taper length should be noted separately, a description of the horizontal and vertical geometry, roadside features, adjacent land use, and an inventory of existing traffic



control devices, including signs and pavement markings. An Existing Conditions Diagram should be presented, along with photographs of the existing site conditions.

Previous Studies: DelDOT files should be reviewed to determine if the location was previously studied, or if signal agreements exist for the intersection. The findings of previous studies or agreements should be documented.

Anticipated Development: The technical memo or presentation should summarize all known future development in the project area that would result in changes in traffic volumes at the intersection. This section is particularly important for studies pertaining to Developer / Subdivision Projects where the signal justification is based on projected traffic volumes.

Traffic Data: A brief summary of the existing traffic counts and future projected intersection traffic volumes (if applicable) should be included in the report, including an identification of the peak hours. Traffic data should be less than two (2) years old.

Crash Data: The technical memo or presentation should summarize the key trends in the crash data obtained for the study and include a crash diagram. At least three (3) years of data should be obtained from DelDOT's Traffic Design Resource/HSIP Group. Individual police reports may be provided in accordance with Delaware Code, if necessary, to establish a better understanding of the crash trends. Highway Safety Manual evaluations, which may include a predictive method analysis, should also be performed.

Observations: The technical memo or presentation should include a brief discussion of significant items noted during field observations related to physical features and/or traffic operations.

Warrant Analyses: A statement identifying which of the nine (9) signal warrants from the DE MUTCD are satisfied at the study location should be included. A detailed summary of the signal warrant analyses should also be included as an attachment.

Operational Analyses: The technical memo or presentation should include a summary of the existing intersection operations, identifying any capacity, delay, or queuing deficiencies. Proposed operations should also be summarized. For locations where signalization is recommended, the results should clearly demonstrate the expected improvements based on the critical measures of effectiveness. Additional information that may be summarized includes the results of spot speed studies, delay studies, and gap studies. Critical Movement Summation (CMS) calculations should also be provided if a signal is warranted (refer to **Appendix I**).

Intersection Sight Distance: A comparison of the available intersection sight distance to the minimum values specified by AASHTO should be included.

Alternative/Short-Term Improvements: The technical memo or presentation should identify any short-term improvements that could be implemented in lieu of signalization.



Recommendation: The report should include a recommendation for improvements based on the findings of the study.

Intended Signal Operations (Phasing / Timing): The technical memo or presentation should include a description of the preliminary signal timing and phasing plan, including left-turn treatments. The final signal timing plan will be developed later in the design phase.

Intended Lane Configurations: The technical memo or presentation should include a description of the intended intersection lane configuration, highlighting proposed changes from existing conditions.

Preliminary Design Considerations: A summary of issues identified during the site visit which may impact the design process should be outlined. Key issues may include utilities, intersection geometry (skew/lane alignment), physical constraints, pedestrian features, and system compatibility.

b. Signal Design Request Form

If a traffic control signal is recommended by the Traffic Signal Justification Study a Signal Design Request Form should be initiated and approved by both the Chief of Traffic Engineering and the Chief of Traffic Operations. The signed Signal Design Request Form serves as a formal handoff between the Studies Group and the Design Group to initiate the design phase. See **Appendix J** for DelDOT's Signal Design Request Form.

8. Signal Phasing Change

Based on the corridor or operational changes, adjustment to signal phasing may be required. Since the need for phasing change can be derived for a variety of reasons, a field observation should be conducted to observe the operational and geometric characteristics. The field observation should occur during the hours of the day when operational problems occur. Based on the field observations, the type of study to be conducted can be determined. The study should clearly demonstrate the safety and operational benefits of the phasing change being implemented.

9. Signal Deactivation

A study is also required in cases where the deactivation of an existing traffic control signal is proposed. The requirements for this type of study are similar to those of a traditional Traffic Signal Justification Study. The study should clearly demonstrate the safety and operational benefits of deactivating the existing signal. Complete guidance on the procedure to be followed for signal deactivation is included with this manual in **Appendix K**.



B. Types of Signal Projects

This chapter of the Traffic Design Manual defines the nine types of traffic control devices most commonly used by DelDOT. Chapters IV-C and IV-D of this Manual outline the specific design elements required to prepare a traffic signal design per DelDOT standards.

1. Traffic Control Signal

A traffic control signal is defined as any highway traffic signal by which traffic is alternately directed to stop and permitted to proceed. Traffic is defined as pedestrians, bicyclists, vehicles, streetcars, and other conveyances either singularly or together while using any highway for purposes of travel. Traffic control signals are DelDOT's most-common type of signal project. Projects may include new signals at an existing or proposed intersection or modifications to an existing signal.

All new signals installed in Delaware must be justified based on an engineering study. The required elements of the study are outlined in Chapter IV.A (Traffic Signal Justification Study) of this Manual.

For additional information regarding traffic control signal design elements, refer to the DE MUTCD, Chapter 4D.

2. Hazard Identification Beacon (HIB)

A Hazard Identification Beacon (HIB) is a type of signal indication used to warn motorists of potentially hazardous conditions downstream. Beacons used for hazard identification should only be used as a supplement to other appropriate warning or regulatory signs and devices except for STOP, DO NOT ENTER, WRONG WAY, and Speed Limit signs. Except for school speed limit signs, beacons should not be included within the border of the sign or device. The use of horizontally aligned beacons with School Speed Limit signs (S5-3-DE, R1-2 with S4-3 and S4-4) is no longer permitted on state-maintained roadways in Delaware for new or retrofitted sign installations. Instead, if used with a new or retrofitted School Speed Limit sign assembly, the signal indications shall be vertically aligned per Section 4L.04 of the DE MUTCD. The exception to this standard is School Speed Limit signs that are longer horizontally than vertically, which is typically the case for overhead installations. In these cases, horizontally aligned beacons are still considered acceptable and consistent with both Parts 4 and 7 of the DE MUTCD.

When used at intersections, beacons should not face conflicting vehicle movements. Warning beacons are yellow in color and should have a circular 12-inch diameter visible face. Two



beacons aligned either horizontally or vertically and flashing alternately can be used for added emphasis. A system of four beacons, flashing alternately between the top left/bottom right and top right/bottom left may also be used, typically mounted overhead.

If the installation is temporary or short-term, the use of solar-powered devices may be considered with monitoring for potential removal in the future. For long-term or undefined usage lengths, hardwire power should be deployed.

Typical applications of Hazard Identification Beacons include alerting motorists of a traffic control signal ahead, warning vehicles of a sharp curve (horizontal or vertical), warning vehicles of inadequate sight distance for side streets, warning vehicles of flood-prone areas, warning motorists of school speed limits, or denoting the end of an expressway. HIBs should only be used when an engineering study shows a demonstrated need because these types of traffic control devices can lose their effectiveness if overused.

3. Intersection Control Beacon (ICB)

Flashing beacons for intersection control may be used at locations where traffic volumes or physical conditions do not warrant traffic control signals, but crash history indicates a possible hazard. These beacons consist of one or more circular yellow or red lenses, typically with 12 inches of visible diameter. They should be used only at intersections to control two or more directions of travel. If multiple red beacons are used on a given approach, they must flash concurrently, because alternately flashing red beacons are reserved for rail crossings and pedestrian hybrid beacons. The application of intersection control beacons should be limited to the following:

- Yellow indication on one route (normally the major), red for the remaining approaches
- Red for all approaches, if a multi-way stop is justified

A stop sign shall be used on any approach with a permanently flashing red beacon. Intersection control beacons are generally suspended over the roadway, but pedestal mounting is acceptable under appropriate conditions (refer to recommended mounting heights described previously under the heading “Hazard Identification Beacon”). When a pedestal mount is used, the pedestal should not be located in the roadway unless within the confines of a traffic or pedestrian island. Refer to the DE MUTCD, Section 4L.02, for additional information on the design of Intersection Control Beacons.

Intersection Control Beacons should only be used when an engineering study shows a demonstrated need for extra emphasis beyond the typical sign control because these types of traffic control devices can lose their effectiveness if overused. For additional guidance,



please refer to the “Intersection Control Beacon Effectiveness Study” (June 2019), https://deldot.gov/Programs/DSHSP/pdfs/otherIntersection/ICB_ResearchReport_20190628_Package.pdf?cache=1666143304303.

4. Emergency-Vehicle Signals and Hybrid Beacons

An emergency-vehicle traffic control signal is a special traffic control signal that assigns the right-of-way to an authorized emergency vehicle. An emergency-vehicle traffic control signal may be installed at a location that does not meet other traffic control signal warrants such as at intersections, entrances, or other locations to permit direct access from a building housing the emergency vehicle.

Some fire and rescue signals currently in use in the State of Delaware do not conform to the current MUTCD standards. Non-compliant fire and rescue signals should be upgraded to meet the current standards if they fall within the limits of a Capital Project.

An alternative to installing a full traffic control signal for emergency vehicles would be the installation of an emergency-vehicle hybrid beacon. An emergency-vehicle hybrid beacon may only be installed if the conditions justifying an emergency-vehicle traffic control signal are met. When new emergency-vehicle or emergency hybrid beacons are requested by emergency service agencies, funding for new installations is typically provided by community transportation funds as approved by area legislators.

Refer to the DE MUTCD, Chapter 4G, for additional information on the design and operation of fire and rescue signals and hybrid beacons.

5. Railroad Crossing

Part 8 of the DE MUTCD provides a detailed description of all the design elements required for Railroad Crossings. Many of the design elements are the responsibility of the railroad company. However, when a traffic control signal is required, the design is performed by the DelDOT Traffic Section.

As noted in Section 8C.09 of the DE MUTCD, traffic control signals may be used instead of flashing-light signals to control road users at industrial highway rail grade crossings and other places where train movements are very slow, such as in switching operations. The appropriate provisions relating to typical traffic control signal design, installation, and operation shall be applicable where traffic control signals are used to control road users instead of flashing-light signals at highway-rail grade crossings. Traffic control signals shall not be used instead of flashing-light signals to control road users at a mainline highway-rail grade crossing.



Exempt railroad crossings require a standard traffic control signal, with green, yellow, and red indications to control traffic, in addition to the standard railroad crossing design elements.

If a highway-rail grade crossing is equipped with a flashing-light signal system and is located within 200 feet of an intersection or midblock location controlled by a traffic control signal, the traffic control signal should be interconnected via “fail safe” (i.e., normally closed) circuits, and the normal operation of the traffic signals controlling the intersection should be preempted to operate in a special control mode when trains are approaching, in accordance with Section 4D.27 of the DE MUTCD. The preemption sequence is extremely important to provide safe vehicular and pedestrian movements. Such preemption serves to ensure that the actions of these separate traffic control devices complement rather than conflict with each other.

If a highway-rail grade crossing is more than 200 feet from an intersection, but an engineering study indicates that queues may extend to the tracks, the Designer should consider the implementation of one or more traffic control treatments, including signal pre-emption, signage (R8-8, “Do Not Stop on Tracks”), or Hazard Identification Beacons, to warn motorists of the railroad crossing. For more information, refer to the *Railroad-Highway Grade Crossing Handbook* developed by FHWA or contact DelDOT’s Railroad Coordinator.

6. Movable Bridges

Traffic control signals for movable bridges (often referred to as “draw bridges”) are a special type of highway traffic signal installed to notify road users to stop because of a temporary road closure, rather than alternately giving the right-of-way to conflicting traffic movements. The designer should coordinate with the appropriate maintenance district to include other devices such as cameras, sensors, etc., as needed. The signals are operated in coordination with the opening and closing of the movable bridge, and with the operation of movable bridge warning and resistance gates, or other devices and features used to warn, control, and stop traffic.

A movable bridge resistance gate provides a physical deterrent to road users when placed in the appropriate position. The movable bridge resistance gates are considered a design feature and not a traffic control device; requirements for them are contained in AASHTO’s “LRFD Movable Highway Bridge Design Specifications.” Refer to Section 4J.02 of the DE MUTCD for additional information on the design of traffic control at movable bridges.



7. Temporary Signal

A temporary signal is defined as a traffic control signal that is installed for a limited time period. Temporary signals may be designed and constructed for a specific location or they may be portable signals that can be easily transported and used at multiple locations. If non-portable temporary signals are used, they would typically be designed with wood poles if possible. All temporary signals should be justified by an engineering study, and typically should be designed to provide detection and communication, similar to permanent signals.

Common uses for temporary signals include providing traffic control for haul road access locations and for site access to a location where the permanent access is under construction

Temporary signals may also be used to provide temporary traffic control for two-way traffic using a single travel lane during construction, such as during bridge rehabilitation or replacement. Sight distance across or through the one-lane, two-way facility should be considered, along with the approach speed and sight distance approaching the facility when determining whether traffic control signals should be installed. A traffic control signal may be used if gaps in opposing traffic do not permit the flow of traffic through the one-lane section of the roadway, even if the location does not meet the traditional nine MUTCD warrants for signalization. Temporary traffic control signals may be preferable to flaggers for long-term projects and other activities that would require flagging at night. Additional information regarding the design for temporary signals is provided in Sections 4D.32, 4H, and 6F.84 of the DE MUTCD.

8. Innovative Intersection Safety Treatments

Recently, FHWA has conducted research to identify new technologies and techniques to improve intersection safety. These innovative intersection safety treatments show promise for improving safety, but comprehensive effectiveness evaluations are not currently available.

Two examples of treatments currently under consideration (Rectangular Rapid Flash Beacons and High-Intensity Activated Crosswalks) are discussed in this section. As other types of innovative intersection safety treatments are developed, they will be considered on a case-by-case basis for use in Delaware, including a review of current Federal guidance, and must be approved by the Chief of Traffic Engineering.



a. Rectangular Rapid Flash Beacons (RRFB)

Rectangular Rapid Flash Beacons (RRFB) are user-actuated amber LEDs that supplement warning signs at unsignalized intersections or mid-block crosswalks. They can be manually activated by pedestrians by a push button or passively by a pedestrian detection system. RRFBs use an irregular flash pattern similar to emergency flashers on police vehicles. They are a lower-cost alternative to traffic signals and hybrid signals and have been shown to increase driver-yielding behavior at crosswalks significantly when supplementing standard pedestrian crossing warning signs and markings.



In March 2018, FHWA granted blanket basis approval for all locations in Delaware under the technical conditions contained in IA-21.3 “Rectangular Rapid-Flashing Beacons at Crosswalks – DE DOT (Statewide)” for usage of RRFBs. The approval allows for statewide usage of RRFB as a warning beacon to supplement standard pedestrian crossing warning signs and markings at either a pedestrian or school crossing; usage where the crosswalk approach is not controlled by a yield sign, stop sign, or traffic control signal; or at a crosswalk at a roundabout. As a condition of the approval, a comprehensive list of RRFB locations is required to be maintained. For additional information, refer to the FHWA Report FHWA-SA-09-009 dated May 2009 with update in June 2012, to address modification in RRFB flash pattern.



SR 72 at Farm Lane, Newark

b. Pedestrian Hybrid Beacon (HAWK)

The pedestrian hybrid beacon uses traditional traffic and pedestrian signal heads but in a non-traditional configuration. It includes an overhead sign instructing motorists to "stop on red"



and an overhead "pedestrian crossing" sign. An example of a pedestrian hybrid beacon is shown to the right.

When not activated, the beacon is dark. The pedestrian hybrid beacon is activated by a pedestrian pushbutton or passive pedestrian sensor, at which time the overhead beacon begins flashing yellow and then solid yellow, advising drivers to prepare to stop. The beacon then displays a solid red indication and shows pedestrians a "Walk" indication. Finally, an alternating flashing red signal indicates that motorists may proceed when safe, after coming to a full stop. During this alternating flashing red phase, the pedestrians are shown a flashing "Don't Walk" indication with a countdown indicating the time left to cross.

As part of the April 2020 "HAWK Pedestrian Signal Compliance Review" (May 2020), http://deldot.gov/Programs/DSHSP/pdfs/OtherPedProjects/HAWK_Study_Report_May2020.pdf?cache=1592402385351, the Department examined both pedestrian and motorist compliance at all HAWK signals in Delaware. Based on the observed findings of motorist behavior, poor pedestrian compliance, and minor changes in pedestrian/bicycle crash rates, **it was recommended that HAWK signals no longer be installed at intersections in Delaware.** It is also recommended that the existing locations be re-evaluated for conversion to full traffic signals or Rectangular Rapid Flash Beacons.



C. Preliminary Design Plan Elements

When developing preliminary signal design plans, there are numerous elements and design factors that should be taken into consideration. The design elements presented in this chapter of the DelDOT Traffic Design Manual represent the minimum that should be incorporated into all preliminary design plans. Additional design elements may also be included, at the discretion of the Designer, DelDOT, or other interested parties, based on project-specific needs.

1. Pole Design

a. Type

The type of signal supports used on a project is a major consideration in the design process. Some factors involved in the selection of an appropriate pole type include the location of overhead utilities, intersection geometrics, the proposed location of traffic signal heads, constructability, aesthetics, and local requirements. The three primary pole types are described below.

Mast Arms

Mast arms allow for a rigid mounting of signal heads and signs. They allow for the far-side deployment of signal equipment and have a more aesthetically pleasing look to the public. Mast arms can also minimize conflicts with overhead utilities because of the lower conflict height. Additionally, mast arms require less maintenance by the Department. Intersections with unusual geometrics may require adjustment of arm angles to align signal heads in the desired position. Mast arms should be considered for all new signal installations and signal reconstructions. Mast arm box designs should be considered first and foremost, with alternative mast arm arrangements looking to achieve box design as secondary options. However, in the selection process, consideration must be given to other pole types if extreme arm angles will be required, if minimum vertical roadway clearance cannot be adhered to, or if the pole placement would be within the active clear zone. Single-arm designs that are placed diagonally across the intersection should only be used as a last resort.

Strain Poles

Strain poles with span wires can provide flexibility in the signal design process at wide intersections and during the construction process when signal heads may require multiple repositionings. Strain poles may also provide more options at locations with unusual geometrics. However, the non-rigid mounting of signal heads tends to cause



more maintenance issues, is not the preferred option of the Department. If used the size of the strain pole chosen should be based on span wire sag to ensure that the signal heads will hang properly between the maximum height for signal housing equipment (25.6 feet) and the minimum 15-foot clearance above the pavement (refer to Chapter IV-C.2.e of this Manual for additional information on the vertical placement of signal heads; a 17-foot minimum clearance to the bottom of the signal head is preferred in Delaware). Sag for new designs should be calculated at 5 percent. For signal rebuilds utilizing existing equipment, a minimum of 3 percent sag may be allowed if the 5 percent cannot be achieved. The Designer must obtain approval from the Chief of Traffic Engineering under these conditions. **Figure IV-1** shows a sample calculation. The Designer shall specify the span length and desired pole mounting height on the design. For a suspended box design, both the pole mounting height and the proposed bull ring mounting heights shall be specified on the design plan. Additionally, a structural analysis may be required to ensure that proper sag is maintained for longer span lengths.



EXAMPLE: HOW TO CALCULATE & MEASURE SAG

Pole-to-Pole Distance: 200 ft
 Pole Height: 32 ft
 Span Attachment Height: 30 ft
 Signal Head Height: 4 ft

5% Sag:
 = Pole-to-Pole Distance x 0.05
 = 200 ft x 0.05 = 10 ft

Distance Between Bottom of Head at Low Point & Pavement:
 = Span Attachment Height - Sag - Signal Head Height
 = 30 ft - 10 ft - 4 ft = 16 ft

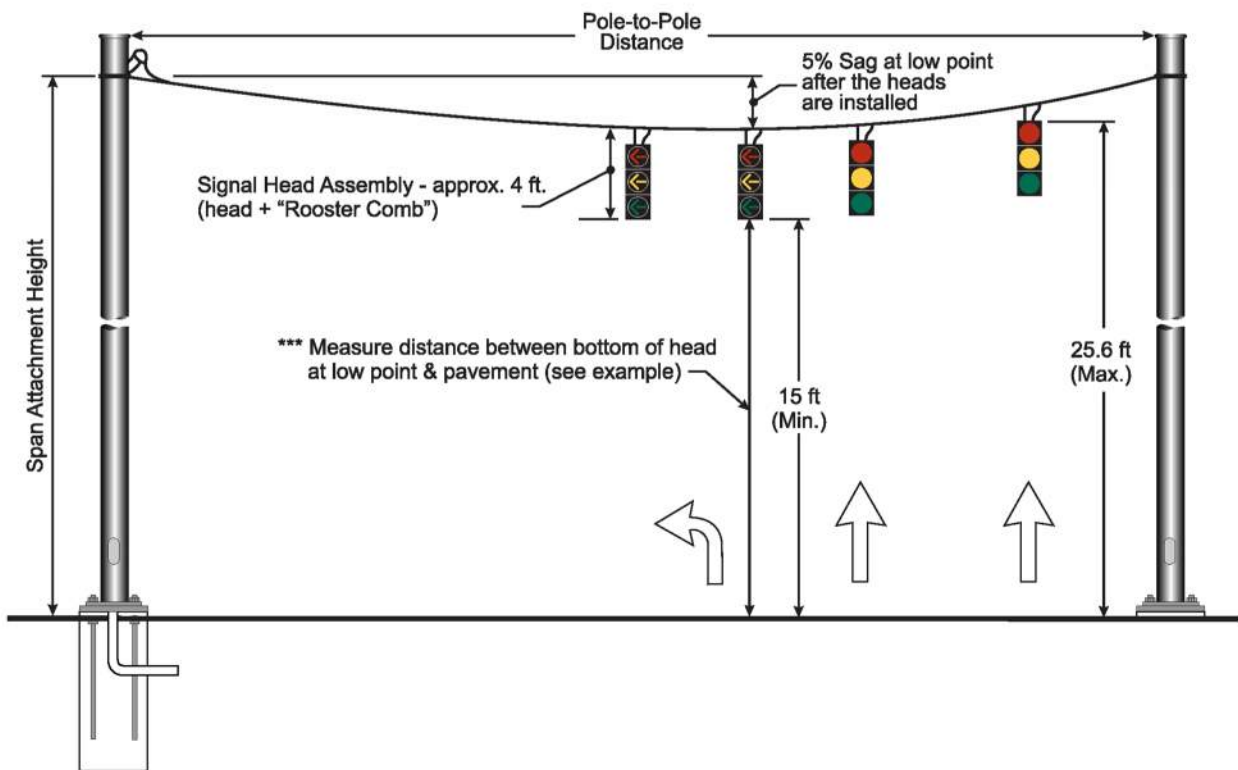

Figure IV-1. Sag Calculation

Pedestal Poles

Pedestal poles with vehicular signal heads may be deployed as a supplemental signal face to enhance visibility in advance or immediately before the signalized location. Pedestal poles' primary usage is for mounting of standard pedestrian signal heads, school flasher assemblies, and additional flasher warning assemblies.



b. Configuration

After the signal support type is chosen, the next step in the signal design process is to determine an appropriate configuration. The most-common layouts and pole choices used by DeIDOT are listed below. The “box” design configurations should be considered for all new signal installations and signal reconstructions. However, in the selection process, consideration may be given to other support types and configurations, in order of preference:

- “Box” Design (mast arm)
- Twin Mast Arms (mast arm)
- “Diagonal” (mast arm)
- “Box” Design (span wire)
- “Suspended Box” Design (span wire only)
- “Diagonal” (span wire)
- Pedestal Pole Supports
- Wood Pole Supports (temporary only)

While there are many different alternative configurations that can be applied, **the mast arm box design should be considered first and foremost**, which allows the signal heads to be placed on the far side of the intersection. **Figure IV-2** shows an illustration of the Department’s standard box design, as well as some of the other potential layouts for signal poles and signal heads.

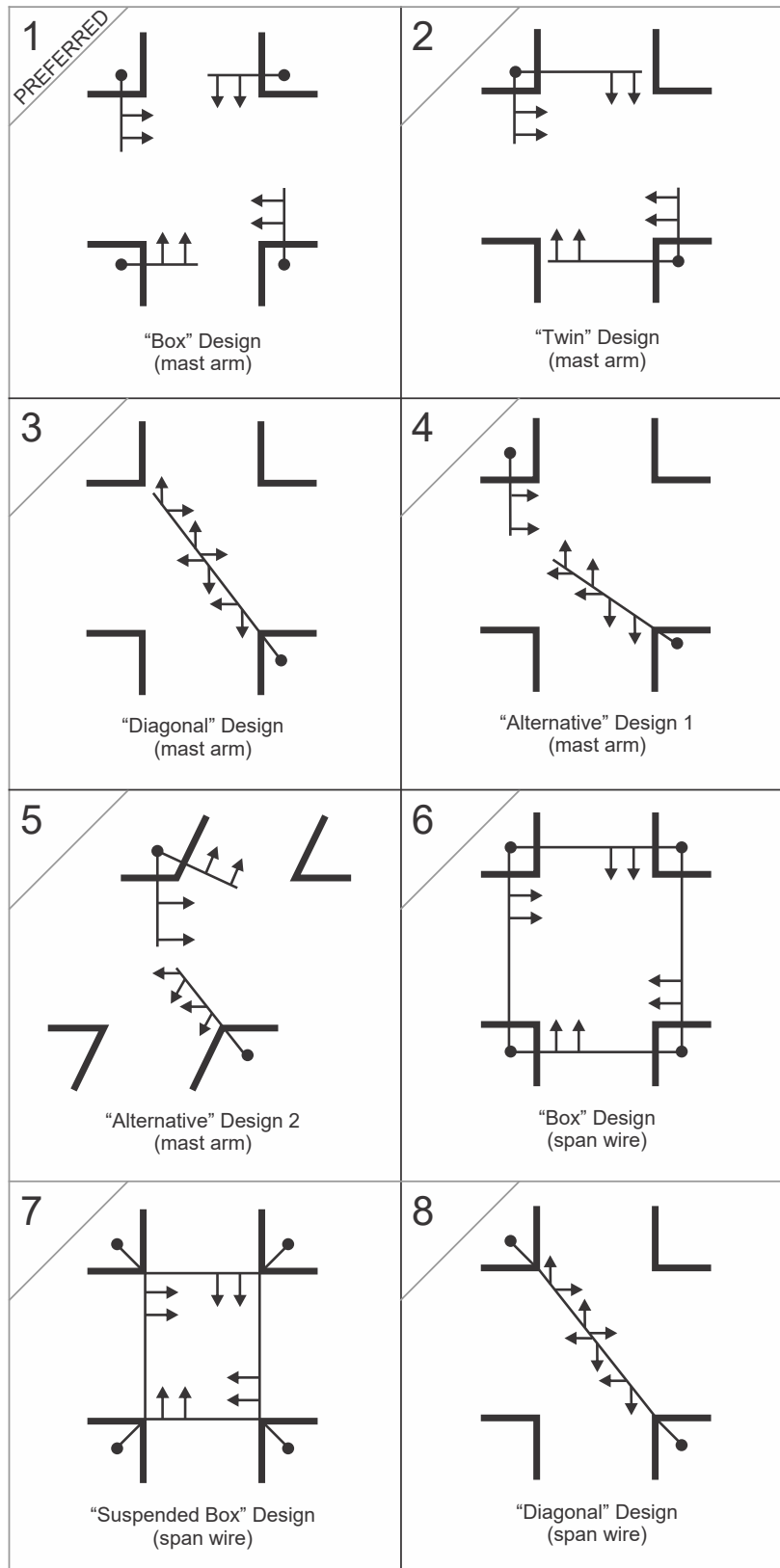

Figure IV-2. Typical Layouts of Signal Poles and Signal Heads



“Box” Design Configuration

The “box” design configurations should be considered for all signal installations and signal reconstructions, as the location allows. The “box” configuration provides excellent lateral placement of signal heads for maximum conspicuity of signal indications, good placement of overhead signs and provides convenient pole locations for supplemental signal head installation.

Mast arms should be considered for all new signal installations and signal reconstructions. Mast arms allow for a rigid mount for signal equipment and signs and provide good lateral support. Mast arm lengths range from 20-foot to 90-foot maximum for single arms with a 60-foot maximum length for twin mast arms. However, for offset intersections and extremely wide intersections, the use of the standard “box” mast arm design may provide challenges. Alternative box designs may be utilized by adjusting the angle of the mast arm or developing twin-arm designs to achieve desired far-side head placement. The Designer should consider all options prior to proposing an alternative mounting type and confirm the proposed configuration falls within the “Mast Arm Loading Configuration Design.” If the configuration exceeds the design load configuration, the Designer shall coordinate with the pole vendor and/or perform structural analysis to verify structural loading is adequate.

Span wires may also achieve a “box” design as an alternative method. If span wires are used, 4 strain poles must be used to achieve the box configuration. Span wires may offer the ability to span wider intersections, but the non-rigid mount of signal equipment and signs can cause additional maintenance concerns. In situations, such as at extremely wide intersections where signal heads are over 180 feet from the stop line reduced visibility can typically be overcome by using the “suspended box” configuration and/or supplemental signal indications.

Where an existing signal is re-designed, typically from a “diagonal X” or “Z” configuration, the preferred “box” design may not be optimal due to the position of the existing strain poles. The resulting signal head placement and/or alignment may not be acceptable. Under these conditions, a “suspended box” may eliminate these constraints.

Other Configurations

If the “box” design cannot be achieved, an alternative configuration may be used. For smaller intersections that have the right-of-way, utility, or geometric constraints, a diagonal configuration may be a suitable alternative. Diagonal configurations can be achieved using a single mast arm or 2-pole span design. Diagonal configurations have a lower installation cost and limit the number of poles required. While the diagonal



configuration will typically allow for adequate head placement, the designer should avoid configurations that may lead to signal head clutter in the middle of the intersection and/or poor visibility of indications from the stop line. The diagonal configuration is typically not suitable for intersections requiring overhead signing. If the configuration exceeds the design load configuration, the Designer shall coordinate with the pole vendor to verify structural loading is adequate.

Other hybrid or unique designs may be required for locations with atypical geometry or significant constraints. However, eliminating signal head clutter, poor visibility from the stop line, and future maintenance issues should be major considerations when proposing alternate design configurations.

c. Placement

1.) Clear Zone

When considering the placement of poles, it is most desirable to have poles located outside of the clear zone. Signal poles may be placed closer to the edge of the roadway if vertical curb is provided and lateral offset guidelines in the AASHTO Roadside Design Guide are met. If a signal pole cannot be located at a sufficient distance from the face of the vertical curb due to geometric or other constraints, the signal pole may be protected using a guardrail or another acceptable form of barrier protection as approved by the Chief of Traffic Engineering. In-house signal plans designed as a part of a capital project should follow the clear zone requirements established by the design engineer of record for the project. Refer to AASHTO's Roadside Design Guide for further information on clear zone and lateral offset requirements in regard to pole placement. For additional information discussing the two roadside concepts, refer to the *Clear Zone, Lateral Offset & Horizontal Clearances Discussion* in DeIDOT's Design Resource Center.

Requirements

For safety reasons, all non-breakaway traffic signal supports should be located outside of the clear zone. All traffic control devices over an open travel lane shall be considered non-break-away for the purposes of locating and protecting the support. This is most critical at locations with high-speed traffic, heavy turning movements, no parking lanes or shoulders, and for locations along the outside of a curve. In these cases, it is highly desirable to place the supports outside the designated roadway clear zone.



Locating non-breakaway traffic signal supports outside of the clear zone is not always practical or feasible, especially in urban or constrained environments where right-of-way or lateral offset is not readily available. In situations such as these, refer to the [Clear Zone, Lateral Offset & Horizontal Clearances Discussion](#) document in DelDOT's Design Resource Center.

Islands and Medians:

The installation of non-breakaway signal supports in islands and medians is not a preferred option unless the clear zone distance can be met and/or guardrail protection can be provided. Typically, this precludes the placement of signal poles in the median, except in situations where the median/island is very large.

Refer to the AASHTO [Roadside Design Guide](#) for additional clear zone information and calculations.

2.) Utility Clearance

Utility clearance is the required distance of signal equipment/components from above and underground facilities. The ability to achieve proper utility clearance, including construction access, will be a major factor in selecting an appropriate signal configuration. The placement of signal equipment shall comply with current local utility companies and National Electrical Safety Code (NESC) clearance requirements. Typically, signal equipment should be at least 10 feet from all primary electric lines, 4 feet from all secondary electric lines, and 2 feet from cable and telephone lines. For underground facilities, a minimum of 2 feet should be maintained for all wet and dry facility feeders. Additional coordination with the DelDOT Utility section or utility companies for underground distribution facilities shall be required.

2. Signal Head Design

a. Number of Signal Heads

A minimum of two signal faces shall be provided for the through movement on each approach to an intersection. If a through movement does not exist on an approach, a minimum of two signal faces shall be provided for the turning movement that is considered the major movement. If there are more than two through lanes on an approach, one signal head per lane should be used.



b. Signal Head Configurations

There are several different signal head configurations that are used by DelDOT. The selection of the appropriate signal head configuration is dependent on the type of signal phasing and the corresponding lane configuration:

- For major and minor street through movements, standard three-section heads with circular indications should be used.
- When protected-permissive left-turn phasing is proposed, a five-section cluster head should be used in combination with a three-section head for the through lanes.
- When protected-only left-turn phasing is proposed, two three-section heads with arrow indications should be used for the turning movement.
- When a right-turn arrow phase is proposed, a five-section cluster head with right-turn arrows should be used in place of the right-hand, three-section head.
- When split-phasing is proposed, a four-section inverted “Tee” head should be used in place of the left-hand or right-hand three-section head to accommodate major movements through the intersection. In cases where there is a double left-turn, or double right-turn, a three-section head with arrow indications is required on the left-hand, or right side, of the inverted “Tee.”
- When flashing red arrow (FRA) phasing is proposed, two 4-section “Tee” heads shall be used for the left/right turning movement in combination with three-section heads for the through lanes.

See **Figure IV-3** on the following page showing the typical signal head configurations. Other signal head configurations may also be allowed if they are consistent with the DE MUTCD.



Three (3) Section		Four (4) Section		Five (5) Section	
Permitted	Exclusive Turn Arrows	Protected / Permitted	Flashing Red	Protected / Permitted	Shared Left / Right Turn Lane (No Thru)

* Used in unusual situations where Right Turn on Red is allowed during some phases and not during others

Legend

- Direction of travel
- SR Steady red
- FR Flashing red
- SR/FR Steady red and flashing red
- SY Steady yellow
- FY Flashing yellow

Figure IV-3. Signal Head Displays

c. Signal Indication Size

For all traffic control signals in Delaware, 12-inch signal indications are the standard and shall be used, except under special circumstances, in which 8-inch signal indications may be permitted based on approval by DelDOT’s Chief of Traffic Engineering. Special circumstances include locations where required vertical clearance cannot otherwise be provided using standard 12-inch indications. Additionally, at an existing signalized location with 8-inch signal indications, the 8-inch indications may be used for the remainder of their useful life, but they shall be replaced with 12-inch indications at the end of their useful life or as part of any signal modification.



d. Visibility

The signal designer should check the roadway curvature and profile when selecting the placement for traffic signal indications to ensure proper visibility on the approach. The geometry of the intersection, including vertical grades, horizontal curves, skewed approaches, and obstructions, shall be considered in determining the position of signal faces. Refer to Table 4D-2 in the DE MUTCD for a table showing the minimum visibility requirements. When minimum visibility cannot be met, refer to Section 4D.12 of the DE MUTCD for treatment options, including the appropriate use of “Signal Ahead” (W3-3) signs.

e. Signal Head Placement

The following guidelines should be followed when determining signal head placement:

- Where a signal face is meant to control a specific lane or lanes of approach, its position should be unmistakably in line with the path of the movement. Guidance related to the specific vertical and lateral placement of signal heads is provided on the following pages.
- Near side signals should be located as near as possible to the stop line.
- Required signal faces for any one approach must be mounted no less than 8 feet apart, measured horizontally between the centers of the face.
- As outlined in the FHWA MUTCD and the DE MUTCD where possible, at least one and preferably both signal displays that control the major movement traffic should be located a minimum of 40 feet and a maximum of 180 feet beyond the stop line.
- Where the nearest signal face is more than 180 feet beyond the stop line, supplemental signal indications shall be required.
- Where both required signal faces are pole-mounted, they shall be on the far side of the intersection, one on the right and one on the left of the driver. This type of design shall only be considered with the prior approval of the Chief of Traffic Engineering.

1.) Vertical Placement

The bottom of the signal head housing (including any related attachments) of a vehicle signal face located over any portion of the highway that can be used by motor vehicles shall be at least 15 feet above the pavement (a minimum of 17 feet is preferred in Delaware). The top of the signal housing for a vehicle signal face located



over a roadway shall not be more than 25.6 feet above the pavement. When the signal head is located between 40 feet and 53 feet from the stop line, the maximum mounting height to the top of the signal housing shall be as shown in **Figure IV-4** below.

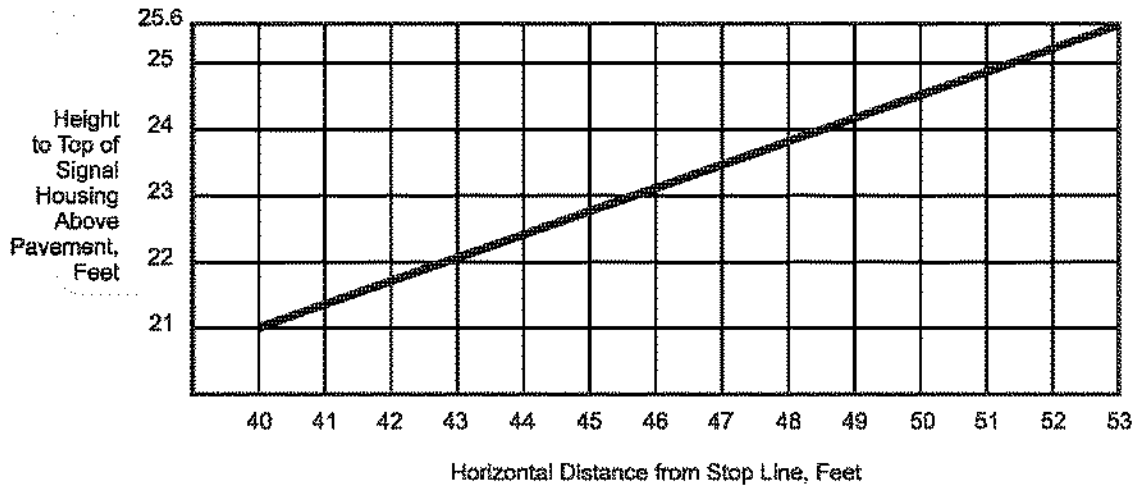

Figure IV-4. Maximum Mounting Height of Signal Housings

The bottom of the signal housing (including brackets) of a vehicular signal face that is vertically arranged and not located over a roadway:

- Shall be at least 8 feet, but not more than 19 feet, above the sidewalk or above the pavement grade at the center of the roadway, if there is no sidewalk.
- Shall be at least 4.5 feet, but not more than 19 feet above the median island grade of a center median island, if located on the near side of the intersection.

The bottom of the signal housing (including brackets) of a vehicular signal face that is horizontally arranged and not located over a roadway:

- Shall be at least 8 feet, but not more than 22 feet above the sidewalk or above the pavement grade at the center of the roadway, if there is no sidewalk.
- Shall be at least 4.5 feet, but not more than 22 feet, above the median island grade of a center median island, if located on the near side of the intersection.

For all span wire designs with backplates and/or signs, under-span tether wires shall be installed.

2.) Lateral Placement

The lateral placement of signal heads depends on the number of lanes on the approach as well as the signal phasing. Some typical configurations for the lateral placement of signal heads are shown in **Figures IV-5a through IV-5o** on the following pages:

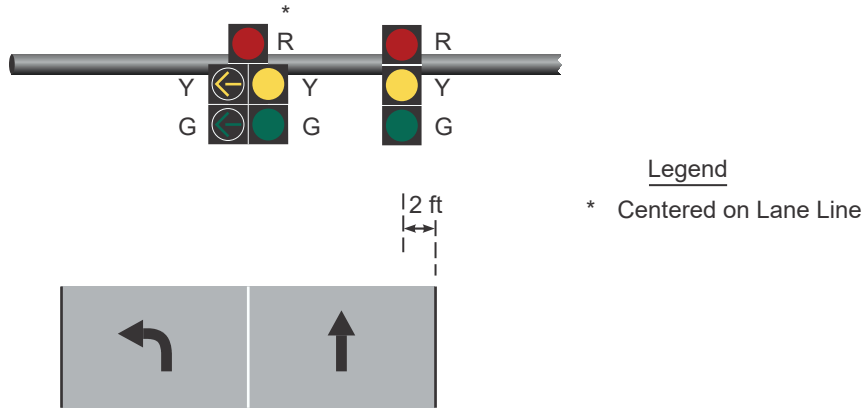

**Figure IV-5a. One Through Lane with One Left-Turn Lane
 (Protected-Permissive Left-Turn Phasing)**

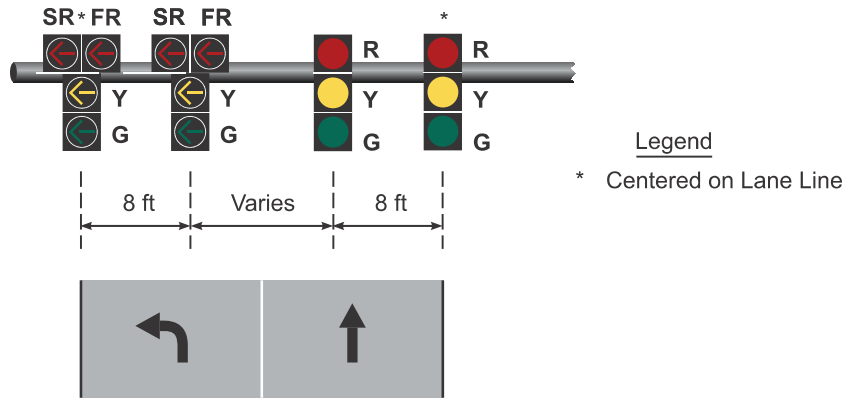

**Figure IV-5b. One Through Lane with One Left-Turn Lane
 (Protected-Permissive Left-Turn Phasing FRA)**

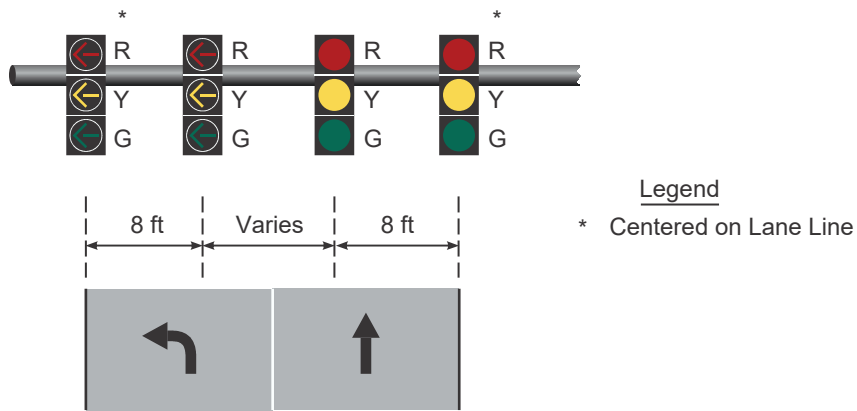

**Figure IV-5c. One Through Lane with One Left-Turn Lane
 (Protected-Only Left-Turn Phasing)**

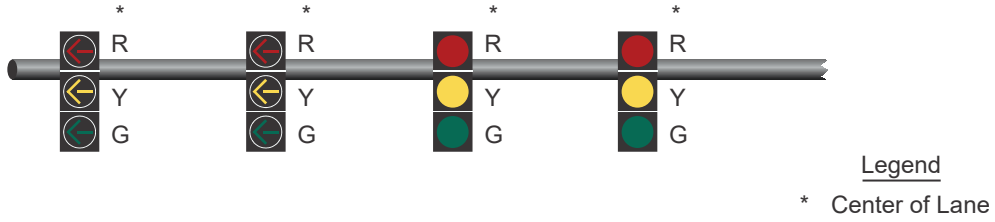

**Figure IV-5g. Two Through Lanes with Two Left-Turn Lanes
 (Protected-Only Left-Turn Phasing)**

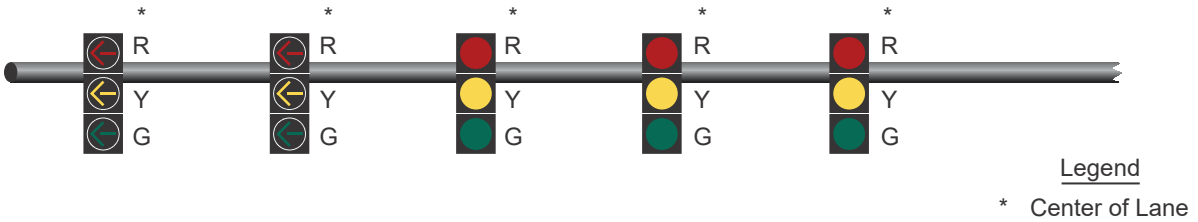

**Figure IV-5h. Three Through Lanes with Two Left-Turn Lanes
 (Protected-Only Left-Turn Phasing)**

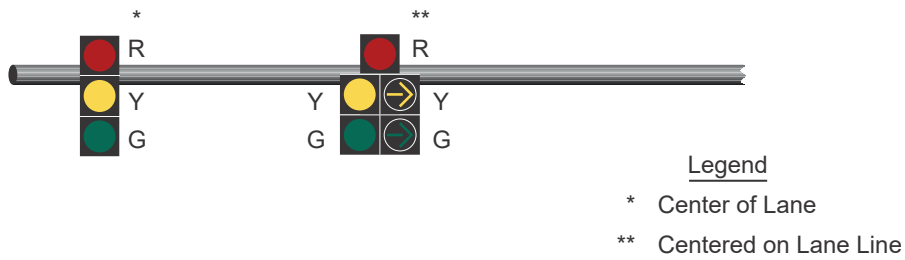

**Figure IV-5i. Two Through Lanes with One Right-Turn Lane
 (Protected-Permissive Right-Turn Phasing)**

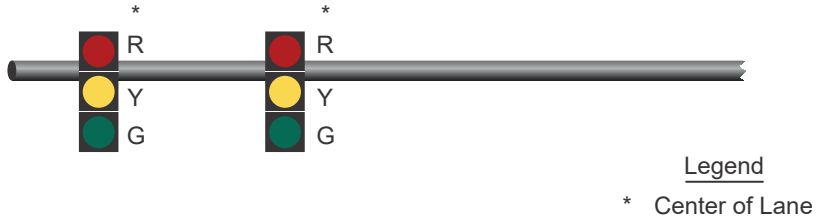

**Figure IV-5j. Two Through Lanes With One Right-Turn Lane
 (Permissive Right-Turn Phasing)**

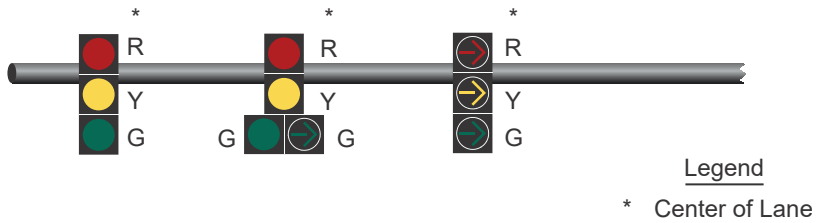

**Figure IV-5k. One Through Lane, One Shared Through/Right Lane, and One Right-Turn Lane
 (Protected-Permissive Right-Turn Phasing)**

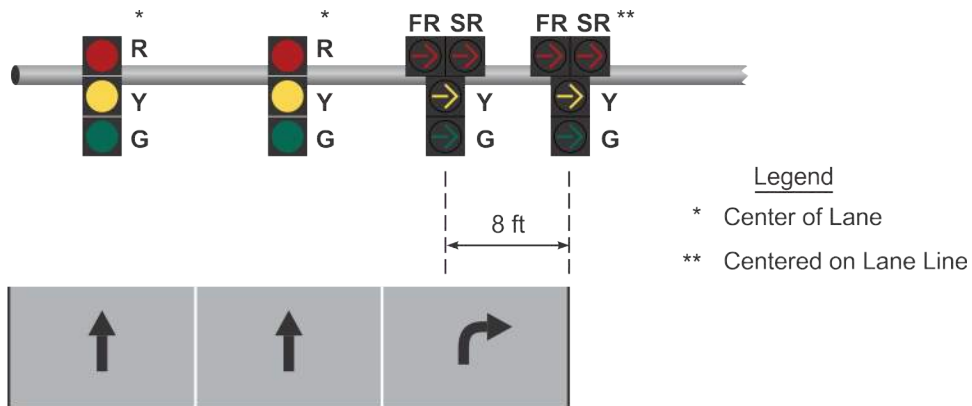

**Figure IV-5l. Two Through Lanes with One Right-Turn Lane
 (Protected-Permissive Right-Turn Phasing FRA)**

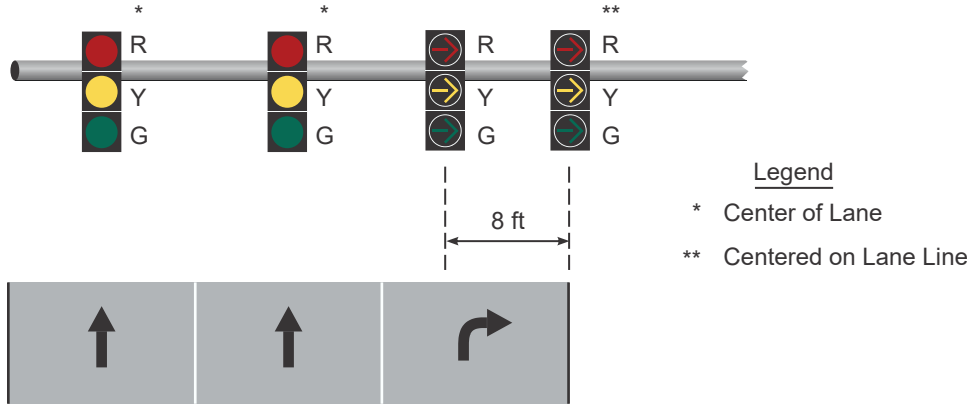

**Figure IV-5m. Two Through Lanes With One Right-Turn Lane
 (Protected-Only Right-Turn Phasing)**

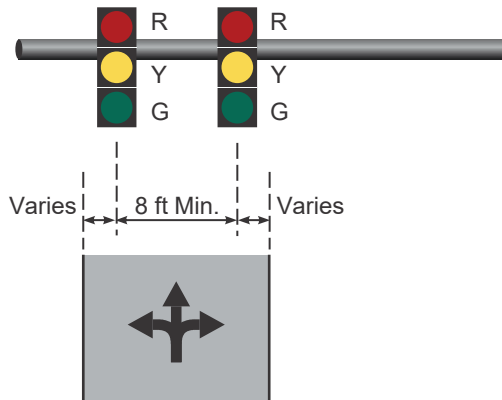

**Figure IV-5n. One Shared Left/Through/Right Lane
 (Permissive Left-Turn Phasing)**

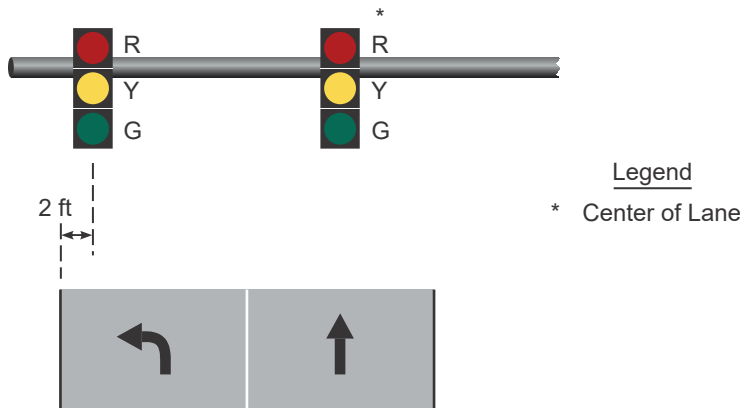

**Figure IV-5o. One Left-Turn Lane With One Through Lane
 (Permissive Left-Turn Phasing)**



Split Phasing

For a signalized intersection operating under split phasing, opposing approaches receive green indications separately without running concurrently. Typically, this occurs on side streets with combination lanes and heavy turning movements. When split phasing is used, the signal head arrangements shown in **Figures IV-6a through IV-6f** below should be used. Refer to Chapter IV-E.3.d of this Manual for additional information regarding the appropriate use of split phasing.

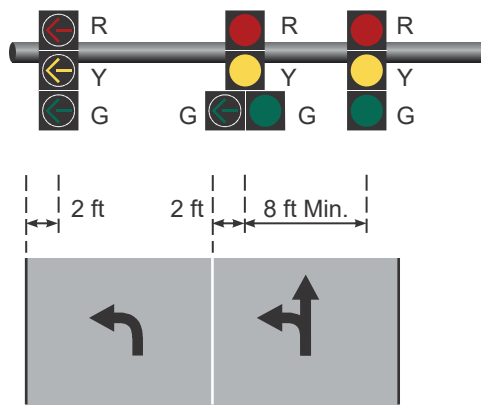

Figure IV-6a. One Left-Turn Lane with One Shared Left/Through Lane (Split Phasing)

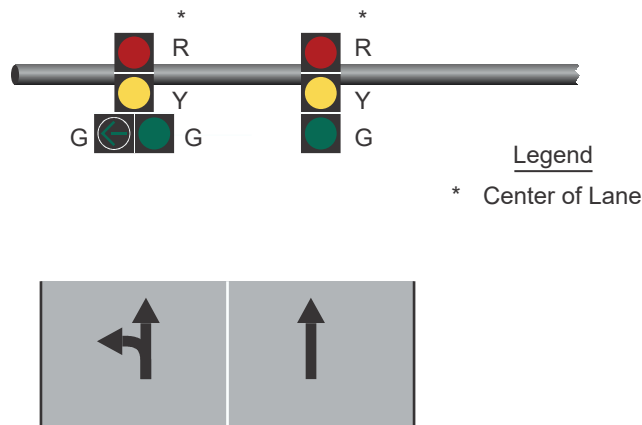

Figure IV-6b. One Shared Left/Through Lane With One Through Lane (Split Phasing)

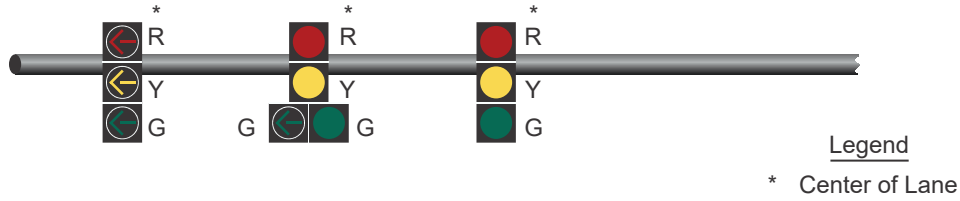

Figure IV-6c. One Left-Turn Lane, One Shared Left/Through Lane, One Through Lane, and One Right-Turn Lane (Split Phasing)

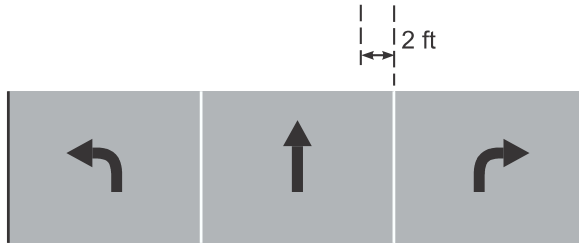
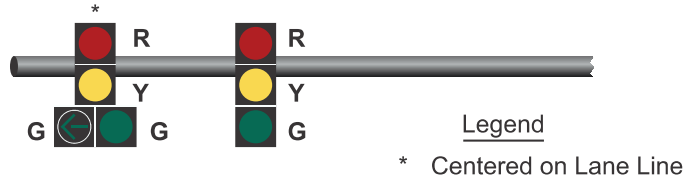

Figure IV-6d. One Left-Turn Lane, One Through Lane, and One Right-Turn Lane (Split Phasing)

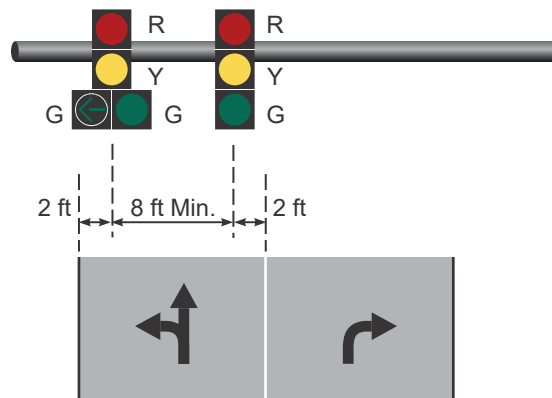
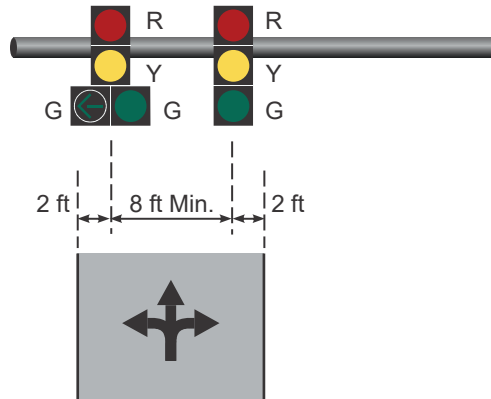

Figure IV-6e. One Shared Left/Through Lane and One Right-Turn Lane (Split Phasing)



**Figure IV-6f. One Shared Left/Through/Right Lane
(Split Phasing)**

Near Side Signal Heads

When used for left turns, near side signal heads should be located adjacent to the far-left lane of the approaching driver. When used for through movements, near side signal heads should be located adjacent to the far-right lane. Per Section 4D.12 of the DE MUTCD, near-side signal faces should be located as near as practical to the stop line.

f. Shielding of Signal Faces

The primary goal in the placement of signal head indications is to optimize the visibility for approaching drivers. Road users approaching a signalized intersection should have a clear sightline to the signal face controlling their movement, and the signal heads should be placed to avoid driver confusion. However, in some cases, geometric constraints at the intersection may force multiple signal indications to be visible by drivers at the same time. In these cases, visors can be used to enhance the visibility of the desired signal head, while obscuring the visibility of other heads.

Visors

A visor should be used on all signal faces to:

- Aid in directing the signal indication specifically to approaching traffic.
- Shade the signal lens from sun, sky, and other conditions which tend to make a lens look illuminated when it is not.
- Shield the lens from motorists on other approaches who might be confused if they were to see the lens.



There are three types of visors; cut-away, tunnel, and full circle. Cut-away visors should typically be used; however, the other types may be necessary in certain cases to further restrict the signal's visibility.

Backplates

Backplates should be used to supplement all vehicular signal heads mounted on mast arms. Backplates should only be used for span wire locations where an engineering study indicates their need to resolve a problem such as where sun glare, bright sky, and/or complex or confusing backgrounds indicate a need for enhanced signal face conspicuity. Backplates shall include a two-inch wide yellow retro-reflective border. If used on span wire, a tether wire shall be used.

g. Optically Programmed Signal Heads

An optically programmed signal head is a signal head that contains optical units which project an indication that is selectively masked so as to be visible only within desired viewing boundaries. Optically directed lenses can provide an optical cut-off of the indication both vertically and horizontally, as needed.

Although optically-programmed signal heads are currently deployed within the state, they are not the preferred shielding method and should only be used upon approval by the Traffic Systems Design Manager and/or Chief of Traffic Engineering. If approved, they shall only be deployed utilizing a mast arm mount.

3. Cabinet Placement

The signal cabinet is an aluminum enclosure that provides housing and protection for signal controller equipment from all forms of outdoor elements.

There are two types of mounting methods for signal cabinets, ground-mounted and pole-mounted. The Department's preferred method is a ground-mounted cabinet which is installed on a concrete base. The typical size cabinet base used by the Department is "Type P". For more information, refer to DeIDOT's Standard Construction details in the Design Resource Center. Additional sizes may be used to address specific design needs but all alternate designs shall be pre-approved by the traffic design representative prior to their usage. All proposed or retrofitted ground-mounted cabinets shall include a cabinet base extension unless there is a specific reason (e.g., limited sight lines) why the cabinet base extension should not be used. Pole-mounted cabinets are attached to either a mast arm or strain pole and are typically smaller in size and used in urban areas. Pole-mounted cabinets may only be used with advance approval from DeIDOT's Traffic Systems Design Manager.



Cabinets should be located as far off the travel edge as possible, outside of the clear zone, to provide protection from errant vehicles. During the design process, coordination shall occur between design, operation, and maintenance on the need for deployment of uninterruptible power system (UPS) design and deployment. Additional factors to consider when determining the location include:

- Safe access by maintenance personnel and maintenance vehicles
- Sufficient right-of-way to permit ready access
- Orientation of cabinet and door (which should be clearly shown on the plan sheet)
- Pedestrian access and ADA compliance (maintaining acceptable sidewalk width and vertical clearance)
- Clear view of the intersection from the cabinet
- Ability to see two conflicting signal indications from cabinet location
- Convenience to power source
- Convenience to communication equipment
- Driver visibility (i.e., intersection sight distance across the corner)
- Clear zone/Lateral Offset
- Need for UPS battery back-up system
- Drainage
- Proximity to low-lying areas
- Door opens away from traffic
- Full-size concrete base for maintenance purposes and to prevent damage by lawn mower equipment

The Designer should also review DNREC Inundation Map, DelDOT Map of Frequently Flooded Roadways, and FEMA Floodplain Maps to assist in determining if the cabinet is in an area that frequently floods or may reasonably be expected to flood more frequently in the future. (Note: Map of Frequently Flooded Roadway currently shows roadway segments that are often closed but not the specific flood area). If further information is needed, staff familiar with the area should be consulted. If a cabinet is planned in an area that currently floods or may flood more frequently in the future, the designer should consider one or more of the following options:

- Relocate the cabinet to a location near field equipment that is least likely to flood (e.g., if one corner of the intersection is at a higher elevation than another corner, consider using the higher elevation corner).
- Use a pole-mounted cabinet



4. Pedestrian Considerations

a. Pedestrian Signal Guidelines

At signalized intersection crosswalks, associated pedestrian traffic signals and accessible landing areas should be provided across all intersection approaches. Where physical conditions (e.g., guardrail, geometric constraints, pedestrian vehicular conflict, etc.) make the presence of pedestrians improbable or a crosswalk would cause undesirable conditions, the crossing at the applicable leg of the intersection may be omitted. The Designer shall exhaust all potential options prior to omission and provide supporting documentation and analyses to the DeIDOT Traffic Section for review and concurrence.

The following crossing designs are undesirable and should be used with caution and only where physical constraints and/or major operational issues would otherwise result:

- Pedestrian signal phases that are designed for pedestrians to stop in the median area
- Diagonally or exceedingly skewed crossings

All new and retrofitted pedestrian signals shall include a countdown timer.

b. ADA Compliance

During the field survey, special consideration should be given to identifying the potential impacts of the installation of new pedestrian signals and/or the modification of the existing facility. All impacts should be identified on preliminary design plans and consideration should be given to how improvements will impact the construction sequence. All proposed crossings should be installed, and all existing crossings should be retro-fitted, to comply with current ADA standards. For information on the design, construction, and maintenance of pedestrian facilities within the public right-of-way, refer to the Delaware Department of Transportation's Pedestrian Accessibility Standards Manual.

The placement of push buttons shall be within reach of pedestrians who are intending to cross and provide clear guidance on which push button is intended for each crossing by positioning the face of the push button parallel with the pedestrian crossing. For placement criteria, refer to Section 4E.08 of the DE MUTCD.

Where feasible, the placement of ramps should take into consideration the installation of future accessible pedestrian signals (APS). APS devices provide non-visual pedestrian timing information in non-visual form through audible tone, verbal message, and



vibrating surface. For more information on APS, refer to Chapter 4 of the DE MUTCD. Requests for APS may be made to DelDOT using the application form provided in **Appendix L**. Requests for APS are addressed by DelDOT on a first-come-first-serve basis and depending on the overall evaluation score.

5. Signal System Interconnection

During preliminary design, consideration should be given to how the proposed or existing signal could be integrated into the ITMS network. All new signals shall be on system. Typically, retrofit designs should also bring signals on system. This may be accommodated by tying into any existing fiber system or building pathway to an adjacent system. However, consideration should be given to avoid significant downtime to the system by the proposed integration. If an existing fiber system is not readily present or cost prohibits the linking to an adjacent pathway, a wireless connection may be a viable option. This could be achieved by a CDMA, 4.9 GHz, or other wireless solution. For all integration into DelDOT's ITMS, the designer shall work with the TMC and the DelDOT Telecommunications Committee on integration solutions and cost.

6. Power Source

New electric service points should be verified early in the design process through coordination with the applicable power companies. For additional information, refer to the DGM 1-27 dated April 7, 2020 included with this Manual in **Appendix M**.



D. Final Design Plan Elements

Final design plans must include all elements necessary to fully construct all components of the traffic signal. During final design, the Designer must update and finalize all elements included in the preliminary design plans and must also include several more-detailed elements to the plan set. The design elements presented in this chapter of the DeIDOT Traffic Design Manual should be incorporated into the final design plans.

1. Conduit Design

A conduit acts as a pathway for electrical and fiber-optic communication cables placed between junction wells, signal pole bases, and the controller cabinet. The DeIDOT Traffic Section uses Schedule 80 polyvinyl chloride conduit (PVC) or high-density polyethylene (HDPE) for all signal and ITS pathways. Rigid galvanized steel conduit will be used for electrical service and loop lead-ins, where applicable.

a. Sizes

DeIDOT Traffic's typical conduit sizes are selected based on the following:

- All proposed signal conduit shall be 4" Schedule 80 PVC when installed by trench or open cut
- All proposed signal conduit shall be 4" HDPE SDR-13.5 when installed by bore. If hand bore is required conduit size may be reduced upon approval by a Traffic Systems Design representative.
- All proposed signal electrical service shall be provided by a single 2" (or larger, as determined by maximum fill capacity) rigid conduit. Rigid conduit is preferred for all conduit when installed above ground. When conduit is installed underground for long distances, Schedule 80 PVC or HDPE may be deployed upon approval of the Traffic Systems Design representative.
- Where applicable, the proposed loop detector lead-in conduit shall be 1 1/2" rigid conduit. See standard construction detail T8 for additional guidance.
- All pole base conduits shall be as outlined in Standard Construction Detail T-5. Once a tie into a junction well has occurred, the remainder of the pathway shall be as stated above.
- 4" Schedule 80 PVC or 4" HDPE SDR-13.5 conduit shall be used for fiber-optic pathways.

For minor signal improvements, smaller conduit sizes may be used upon approval by a Traffic System Design representative.



b. Installation Methods

There are four (4) typical methods for installing signal conduit:

- Trenched – Installation of conduit in grass or dirt
- Bored – Installation of conduit under roadway, pavement or concrete surfaces
- Open Cut – Installation of conduit in roadway, pavement or concrete surfaces where it cannot be bored.
- Banded – Conduit may also be banded to poles and structures, where applicable.

Boring is the preferred alternative to open cutting of roadway, pavement or concrete surfaces. Boring helps to minimize interruption to traffic and damage to surfaces/structures. The installation cost is typically also lower than open cutting. If boring is recommended for the conduits, the Designer must ensure that there will be sufficient room and right-of-way (approximately 10 feet in the direction of the conduit) to place machinery performing the boring operation. If boring beneath pavement or concrete surfaces is found to be infeasible, open cutting the pavement may be the only feasible option. Open cutting also provides the advantage of avoiding conflicts with underground utilities. If open cutting is proposed, the designer should coordinate with District Maintenance staff regarding the issue and any required patching design.

c. Conduit Fill Capacity

The National Electrical Code (NEC) limits the portion of the conduit's cross-section that can be occupied by conductors.

For traffic signal installations, the conduit fill should be limited to **26%** for new conduit and should be limited to **35%** for existing conduit. This will compensate for a potentially large number of conductors, the length of run, and the number of bends. Cross-sectional areas of cables typically used for signal installations are listed in **Table IV-1**, while fill capacities used by DelDOT Traffic are shown in **Tables IV-2** through **IV-2B**.

As an example, if an existing 2.5" PVC Schedule 80 conduit consists of three #14/9 cables and two #18/4 cables, the total area (0.989 sq. in.) would fall under the 35% allowable fill capacity of 1.44 sq. in., with 0.451 sq. in. still available.



Table IV-1 Cross-Sectional Areas of Electrical and Fiber Optic Cables	
No. of Conductors/Wire Size	Area (Sq. In.)
#8/2 UFWG Strand. Bare Copper Ground. Wire	0.250
#18/4	0.049
#14/1	0.049
#14/2	0.091
#14/4	0.119
#14/5	0.139
#14/9	0.297
#14/16	0.389
#6 AWG Stranded Copper	0.051
6 Count Fiber	0.132
24 Count Fiber	0.132
48 Count Fiber	0.132
144 Count Fiber	0.302
CAT	0.102

Table IV-2 Fill Capacities of Typical PVC Schedule 80 Conduit Sizes Used by DeIDOT Traffic		
Conduit Size	Allowable Fill Capacity	Area (Sq. In.)
1.0"	26% (new)	0.18
	35% (existing)	0.24
1.5"	26% (new)	0.45
	35% (existing)	0.60
2.0"	26% (new)	0.75
	35% (existing)	1.00
2.5"	26% (new)	1.07
	35% (existing)	1.44
3.0"	26% (new)	1.67
	35% (existing)	2.25
4.0"	26% (new)	2.93
	35% (existing)	3.94



Table IV-2A Fill Capacities of Typical HDPE Conduit Sizes Used by DelDOT Traffic		
Conduit Size	Allowable Fill Capacity	Area (Sq. In.)
2.0"	26% (new)	0.86
	35% (existing)	1.15
2.5"	26% (new)	1.22
	35% (existing)	1.64
3.0"	26% (new)	1.89
	35% (existing)	2.54
4.0"	26% (new)	3.26
	35% (existing)	4.39

Table IV-2B Fill Capacities of Typical Rigid Conduit Sizes Used by DelDOT Traffic		
Conduit Size	Allowable Fill Capacity	Area (Sq. In.)
1.0"	26% (new)	0.23
	35% (existing)	0.31
1.5"	26% (new)	0.54
	35% (existing)	0.73
2.0"	26% (new)	0.89
	35% (existing)	1.19
2.5"	26% (new)	1.27
	35% (existing)	1.70
3.0"	26% (new)	1.95
	35% (existing)	2.63
4.0"	26% (new)	3.35
	35% (existing)	4.51



2. Junction Wells / Junction Boxes

Junction wells are pre-cast structures placed underground with steel frame lids (Type 1, 4, and 5) or composite lids (Type 7). Junction boxes are placed within concrete barriers with NEMA 4X frames and lids. They act as a point of access to reach cable, to provide a change of direction for a conduit run, or to provide a cable splice location.

a. Types & Sizes

DelDOT Traffic uses four (4) types of junction wells: precast concrete with steel frame and lid (types 1, 4, 5), and precast polymer concrete frame and lid (type 7). The preferred junction well types used by DelDOT Traffic are listed below (see DelDOT's Standard Construction Detail T-1 for additional information):

- Type 1 – 20"x 20": typically used for signal access points beyond the signal cabinet.
- Type 4 – 20"x 42½": typically used for a signal project as a tie-in point for entering the signal cabinet. Also used for pull points for the fiber optics pathway.
- Type 5 – 24"x 16": typically used for signal access points beyond the signal cabinet within narrow medians or constrained right-of-way locations.
- Type 7 – 36"x 60": typically used for the fiber optics pathway as splice points or device tie-in locations.
- NEMA 4X – Size determined by National Electric Code (NEC) requirements.

Under most design projects, the impacted existing steel frame and lid junction wells should be retrofitted to be bonded and grounded. Refer to DelDOT's Standard Construction Detail T-2 for more guidance. For certain signal projects with a small scope of work and with the approval of a Traffic Systems Design representative, there may be no need to modify existing junction wells.

Additional junction well types may be used but would require prior approval from the Traffic Field Operations Manager or Chief of Traffic Engineering.

b. Location

Junction wells for signal design projects should be placed near each signal pole, loop detection splice point, change of direction, roadway crossing of pathway, traffic control device tie-in, and near the cabinet. The maximum spacing between junction wells for signal design projects is 300 feet. The maximum spacing between junction wells for ITS (fiber) pathway is 600 feet. Refer to Chapter V of this Manual for additional details regarding ITS design elements.



3. Detection

Signal detection provides the signal controller with information on the current traffic conditions at the intersection and on the approaches and departures to/from the intersection. Detection should be included in the design of all new and modified signals.

a. Function

The six (6) basic operational functions provided by detection are: 1) Presence, 2) Passage, 3) Sampling, 4) Emergency Vehicle Detection, 5) Pedestrian Detection, and 6) Bicycle Detection.

Presence detection provides the controller information on when a vehicle is present within the designated detection zone. These detectors are typically placed on side streets and left-turn bays prior to the stop line.

Passage detection provides the controller information on when a vehicle has passed through a detection zone. Passage detectors are located at a calculated distance behind the stop line, based on the speed of vehicles approaching the intersection and the grade.

Sampling detection provides the controller with presence and occupancy readings to help aid in determining which signal timing operation should be deployed based on the amount of traffic volume currently within the corridor. Sampling detectors are placed on the departure side of the intersection at a point where vehicles reach free-flowing speeds. Sampling detectors should be strategically located to best serve the system, based on coordination with DelDOT Traffic.

Emergency Vehicle Detection alerts the controller of approaching emergency vehicles, which allows the signal to extend the current green time or to change the signal indications to allow for a green indication to be displayed for the emergency vehicle(s) on the required approach. Typically, all approaches should be designed with emergency vehicle detection.

Pedestrian Detection: is typically accomplished with push buttons located adjacent to a crosswalk that complies with Section 4E.08 of the DE MUTCD. More detail on Pedestrian signal design is provided in Chapter IV-C of this Manual.

Bicycle Detection: is typically accomplished by using vehicle detectors in a designated bicycle lane. When present, bicycle detectors should be placed in bicycle lanes on side streets prior to the stop line. If bicycle lanes are not provided, detector settings should be adjusted to properly detect bicycles.



b. Design

While DelDOT Traffic currently utilizes multiple types of vehicle detection devices, **inductive loop detectors are the Department's standard**. Inductive loop detectors are used for presence, passage, and sampling detection. The loops are formed by saw cutting the surface of the roadway, placing a No 14 AWG wire encased in flexible tubing detector wire into the saw cut, which is then sealed and run to the nearest junction well.

DelDOT Traffic typically utilizes two sizes of inductive loop detectors (see DelDOT's Standard Construction Detail T-9 for additional information):

- Type 1 Loop Detector – Typically a 6-foot by 6-foot loop that can be used for both passage and sampling detection. When used as passage detection, the loop is placed in each of the through travel lanes in advance of the stop line to detect a vehicle approaching the intersection. The placement of the loop is determined by the approach roadway posted speed (refer to **Table IV-3** on the following page). When used as a sampling detector, the detector should be placed on the departure side of the intersection where traffic is expected to reach free flow conditions; however, placement may be adjusted based on field conditions or locations of existing JWs.
- Type 2 Loop Detector – Typically a 6-foot by 25-foot loop is used for presence detection. Type 2 detectors are generally placed at the stop line on minor street approaches and in left-turn lanes, to detect and/or extend green time for the movement being served. The face of the detector is typically placed 2 feet behind the stop line, but placement may be adjusted to address field requirements.

Other types of detection utilized by DelDOT Traffic include Wireless and Non-Intrusive Detectors, which are typically utilized during MOT staging when inductive loops cannot be maintained or require multiple adjustments between stages. Other applications include locations where field conditions do not allow for “intrusive” installations, such as at intersections adjacent to bridge decks or other transitional areas. Non-Intrusive detectors used by DelDOT currently include optical detection and video detection.



Table IV-3 Detector Setbacks	
Speed (MPH)	Detector Setback (feet)
25	90
30	125
35	160
40	200
45	250
50	300
55	350
60	410

NOTES:

Detector setback distances are calculated using the following equations/assumptions:

- Deceleration Rate, d = 12.0 feet per second²
- Reaction Time, r = 1.00 second
- Detector Setback = Deceleration Distance + Reaction Distance

$$= \frac{V^2}{2d} + Vr$$

where V = speed (in feet per second)

Optical Detection is typically used for emergency vehicle detection. Optical detection consists of two primary components: an emitter installed in the emergency vehicle that produces a high-intensity light pulse, and a detector located on the signal. Upon activation, the detector sends a message to the control cabinet to begin a pre-programmed pre-emption sequence. Alternatively, emergency preemption can also be accomplished by the installation of a push button, typically installed within an emergency station. The push button activates an emergency vehicle signal via a hardwired connection.

Video Detection uses a video camera mounted to the signal upright, mast arm, or strain pole to create a digitized detection zone. As vehicles pass through or wait in the zone, a detector call is recorded. For best results, a rigid mount is preferred. Wide approaches with multiple lanes may require more cameras. The Designer shall coordinate with the vendor of the specified video detection equipment to ensure that the proposed layout covers all the required detection zone.



Other detection systems are also available for use in special cases. **Wavetronix, Fisheye, and Microwave Detection** may be used in special circumstances where the use of in-pavement sensors is not feasible or if non-metallic objects need to be detected. In instances, where existing inductive loop detectors are impacted by proposed construction work, **temporary detection** shall be provided as part of the project, unless otherwise approved by the Chief of Traffic Engineering and the Chief of Traffic Operations.

The type of temporary detection shall be based on the need for advance, system, and/or presence detection and consider best fit, system accuracy/reliability, and cost. Temporary detection shall be included as part of a proposed signal plan or as a markup of the most recent archive signal plan on file. The plan or markup together with the traffic statement/cost estimate shall identify and quantify the type, number, and location of detectors, detection zones, procurement cost, installation/removal cost, and maintenance of traffic cost, etc. If a project has multiple construction phases, temporary detection shall be provided during all phases of construction, which may require that the designer submit construction timesheet packages for different phases of construction to the TMC.

After presenting the plan or markup at Project Process, the designer shall coordinate with the vendor/manufacturer to finalize the proposed temporary detection and request a quote for the procurement of the equipment, including any spare units.

Upon notification that a project has been awarded, the designer shall coordinate with Finance that funding is available to purchase the temporary detection equipment, before distributing the handoff with signal plans, traffic statement/cost estimate, quotes, etc. For intersections without proposed signal plans, the designer shall distribute the handoff to the Signal Construction, Signal Maintenance, Design, Finance, and TMC/Operations sections only.

DelDOT's Traffic Contractor shall install the temporary detection ahead of the project's start of construction and shall remove the temporary detection after the permanent detection has been installed by the project. The temporary detection equipment shall be returned to DelDOT Traffic, Dover, Delaware.

4. Wiring

Electrical wiring is an integral component of a signal system. Well-designed electrical wiring systems assure proper signal operation and facilitate maintenance and expansion of the



signal system. The amount and type of electrical wire required for each design is shown in the conduit run schedule on the plan sheet. This schedule shows the wire routing for all related signal equipment back to the controller. The following section of the report outlines DelDOT’s preferred standard practices for wiring. The most common types and sizes of cable used by the department are listed below in **Table IV-4**. For all new construction projects, the designer should update all wiring to comply with current DelDOT electrical standards. For minor retrofit projects, existing wiring may be retained if deemed adequate by a DelDOT Traffic Representative.

Device	Cable Type	Size	Volt. (AC)
HIB, Jumper Wire	4-Conductor Electrical Cable	No. 14 AWG ⁽²⁾	600
Pedestrian Signal Head and Push Button (1 way) per direction	5-Conductor Electrical Cable	No. 14 AWG ⁽²⁾	600
1- & 2-Section Signal Heads, 3-Sect. Head w/Arrows & Jumper Wire (mast arm)	4-Conductor Electrical Cable ⁽¹⁾	No. 14 AWG ⁽²⁾	600
4- and 5-Section Signal Heads (mast arm)	9-Conductor Electrical Cable ⁽¹⁾	No. 14 AWG ⁽²⁾	600
Signal Heads (span wire)	16-Conductor Electric Cable	No. 14 AWG ⁽²⁾	600
Loop Wire Lead-In Cable	1-Conductor (Aluminum shielded)	No. 14 AWG	600
Loop Detector Home-Run Cable	2-Conductor (Aluminum shielded)	No. 14 AWG	600
Opticom Detector	4-Conductor Detector Cable	No. 18 AWG	300
Grounding	Strand. Bare Cop. Gnd. Wire	No. 6 AWG ⁽²⁾	----
Power Feed (disconnect to cabinet)	2-Conductor Electrical Cable	No. 8/ 2 UF w/G ⁽²⁾	110/220
Electrical Service (transformer to disconnect)	1-Conductor Electrical Cable	No. 8 THHN w/G ⁽³⁾ or No. 6 Triplex Service Cable ^{(2) (3)}	110/220

- (1) – Consideration should be given to increasing the number of conductors needed in mast arm installations for spare and future use.
- (2) – For longer runs, a heavier gauge cable may be required to reduce voltage drop.
- (3) – Cable determined by power company providing service.



a. Mast Arm Pole Cabling

The signal cables connecting the signal cabinet and each mast arm pole should be designed as follows:

- **Single Mast Arm with a Single Phase:** Use one (1) 9-conductor for the signal head, one (1) 5-conductor for each pedestrian indication and pushbutton, and one (1) 4-conductor for pre-emption devices.
- **Single or Dual Mast Arm with 2 to 3 Phases:** Use one (1) 16-conductor for the signal head, one (1) 5-conductor per each pedestrian indication and pushbutton, and one (1) 4-conductor for each pre-emption device installed.
- **Single or Dual Mast Arm with 4 Phases:** Use two (2) 16-conductors for signal head, one (1) 5-conductor for each pedestrian indication and pushbutton, and one (1) 4-conductor for each pre-emption device installed.

The above-listed signal head cable configurations will serve as the “home run” between the controller and the base of the mast arm pole. At that point, the cable will be spliced with the individual cables that connect with each signal head:

- One (1) 9-conductor shall be run to each five (5)-section signal head
- One (1) 5-conductor shall be run to all signal heads with four (4) or fewer signal indications.

Pre-emption cable and pedestrian signal head indication cable shall be installed as a single continuous run with no splice from each device installed back to the signal cabinet. Jumper (4-conductor) wire should also be included in quantity calculations. Additional wiring configurations may be required for unusual signal designs including near-side and auxiliary signal heads. See **Appendix N** for additional wire cabling design considerations.

b. Span Wire Cabling

The signal cables connecting the signal cabinet and the primary strain pole in a span wire configuration should be designed with two (2) 16-conductor cables. One of these 16-conductor cables will be used to serve two approaches (one major street approach and one minor street approach) while the other 16-conductor cable will be used to serve the remaining approach(es). These two cables typically provide all the conductors necessary to serve all of the signal heads used for most span wire configurations.

Additionally, one (1) 4-conductor cable must be run between the signal cabinet and each pre-emption device. One (1) 5-conductor cable must also be run from the signal



cabinet to each pedestrian indication per corner of the intersection requiring a pedestrian indication. This cable may either be run underground (preferred) or overhead, if necessary. Additional wiring configurations may be required for unusual signal designs including near-side and auxiliary signal heads. See **Appendix N** for additional wire cabling design considerations.

c. Pedestrian Signal

Pedestrian signals in Delaware require one (1) 5-conductor cable spliced in the base per each pedestrian indication(s) and push button(s). Additionally, (1) 4-conductor cable shall run within the pole between the pedestrian head and the pushbutton to the 5-conductor in the base of the pole.

d. Detector Wiring

For detector wiring, a single 2-conductor aluminum shield home-run cable is spliced into each loop detector and run from the junction well to the controller cabinet in a continuous run. No additional splices shall be permitted. All other detection methods should follow the recommended manufacturer requirements to maintain maximum output.

e. Overhead Cabling

Overhead cabling is used with span wire signal installations. Cables installed overhead shall be supported by span wires strung between signal poles. Attachment of signal cables to the span wire shall be by standard lashing methods with galvanized lashing wire. Attachment of cable to the span wire shall be by application of a minimum of five (5) wraps of plastic tape (black in color) at intervals of not more than 24 inches.

The vertical runs of cable to the overhead installation should be routed in conduits with a weather head or routed inside the steel pole. Drip loops shall be formed where the cable enters the weather head to prevent water from running down the cable into the conduit or pole.

In some cases, primarily for interconnection with other intersections or to provide power to the intersection, overhead cabling may also be used. Utility companies typically own existing poles that are located along roadways and joint usage of these poles can usually be arranged with the utility company. There are safety requirements to maintain certain clearances from other utility lines and attachment agreements may be required.



Cables installed overhead between existing poles shall be supported by messenger wires strung between poles. The messenger may be a separate wire used to support the cabling or may be combined with an electrical cable in a common jacket. When combined, the cable has a figure 8 cross-section profile and is therefore termed a “figure 8” cable (see DeIDOT’s Standard Construction Details T-11 and T-12 for additional information).

f. Interconnect

Interconnect provides coordination between traffic signals allowing the ability to establish a time relationship between the signals. All signals should be interconnected through DeIDOT’s TMC. This allows the TMC to implement a standard clock, provides the ability to adjust timings, facilitates troubleshooting, and provides real-time traffic data. Coordination between adjacent signals has proven to be effective in improving the flow of vehicles and reducing vehicle delay and fuel consumption.

Coordination is accomplished through several different methods. Options include a fiber-optic connection (for signals near existing or proposed fiber pathways), CDMA, 4.9 GHz, and 900 MHz wireless connection.

There are some basic principles to be followed when installing coordination interconnect cables:

- All cables shall be terminated inside of an enclosure (control cabinet, splice case, or computer building). This allows for easy termination on terminals and convenient testing points.
- Intermediate splices, other than at junction wells or cabinets, should be avoided.
- Interconnect cables should not be placed into the same conduit with cables that carry secondary line voltage or higher.

Consultation with the Telecommunications Group is required to finalize the design.

g. Grounding

A single No. 6 AWG stranded copper ground wire shall run through all pathways between the cabinet and junction wells and the bases of all pole structures to ensure proper grounding of all wires.

h. Power Feed

DeIDOT’s traffic signals typically draw power from existing, nearby utilities. The signal designer should identify potential sources of power as early in the design phase as possible and coordinate the location, service wire size, and any other specific



requirements with the power provider. For additional guidance on the next steps in the process, refer to DGM 1-27. DeIDOT Traffic Signal Construction with the support of the designer will prepare and deliver power service applications.

The standard signal service for DeIDOT shall be as follows:

Overhead or underground service should be tapped from the nearest utility pole, transformer, or electrical manhole able to provide, 120/240 Volt, single-phase, three-wire service.

A meter, breaker panel, and/or disconnect switch, in weather-rated enclosures, shall be installed on the line side of the service typically within 5 feet (10 feet max) of the utility pole (refer to DeIDOT's Standard Construction Detail T-17 for additional guidance). For designs where the control cabinet is located more than 50' from the power source or where a disconnect is not easily accessible, an additional secondary disconnect, or breaker panel shall be required. Underground conduit shall transition to Rigid Galvanized Steel (RGS) before transitioning up to the service. The designer should provide the pole number for utility poles used as power sources.

5. Phasing

Signal phasing assigns the right-of-way to one or more movements during a signal cycle. The phase numbering and sequencing are shown in a diagram in the upper right-hand corner of the signal plan sheet and shall follow the NEMA phasing conventions as adopted by DeIDOT Traffic. For detailed information on phasing, refer to Section IV-E.3 of this Manual.

If the side street phasing is split, the side streets use Phases 3 and 4 only. If the side streets run concurrently, phase 4 and 8 shall be utilized. At a "T" intersection, the side street is typically Phase 4. In a box under the NEMA phasing diagram, the following note should be inserted:

1. Phases associated by a solid line will not operate concurrently.
2. Phases associated by a dashed line may operate concurrently.

On the plan sheet, the Designer should connect the phase circles by the appropriate line type.

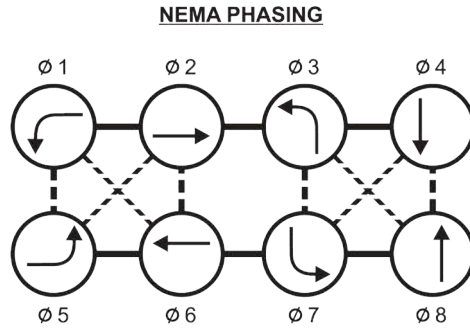
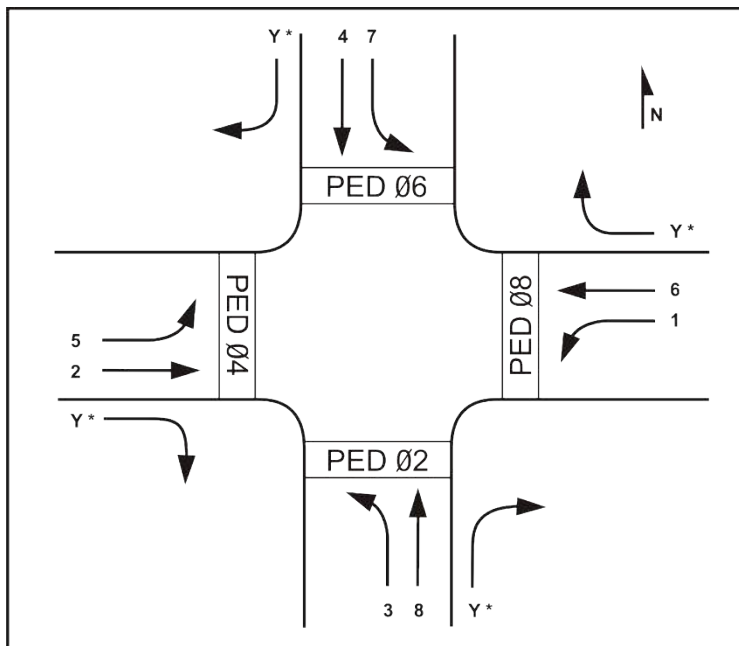

Figure IV-7. Standard NEMA Phasing Convention

The NEMA phasing diagram shown in **Figure IV-7** corresponds with the following intersection movements shown below in **Figure IV-8**. Atypical phasing requires coordination between the designer and TMC.



* Only shown when right turns are YIELD-controlled

Figure IV-8. Typical Intersection Movements and Corresponding NEMA Phasing Convention

6. Control Cabinet

Types

For all signal projects, a 16-phase, fully actuated signal controller will be used. For all retrofits and/or signal modification projects, signal controllers should be upgraded unless otherwise agreed to by the TMC. Controllers will typically be housed in a based-mounted cabinet with base extension, unless there is a specific reason (e.g., limited sight lines) why



the base extension should not be utilized. In situations where there is insufficient space, the potential for flooding, or other geometric or environmental constraints, a pole-mounted cabinet may be used. On the signal plan, the cabinet type shall be shown inside the cabinet symbol. All cabinets should be connected to the DeIDOT TMC. The preferred method of connection is via a fiber line, but if a fiber line is not feasible due to the location of the signal, then a CDMA, 4.9Ghz, or other wireless connection should be considered. See Chapter V Section A.2 for additional guidance.

Conduits

All proposed Type P signal cabinet bases (refer to DeIDOT's Standard Construction Detail T-4) shall have a minimum of four (4) conduits access points. The typical layout shall be as follows. All proposed Type P signal cabinet bases shall be connected directly to a type 4 junction well with a minimum of four (4) 4" Schedule 80 PVC conduits providing direct access. Additionally, a single 2" (or larger, as determined by maximum fill capacity) service conduit, rigid galvanized steel preferred, shall provide direct access to the base or via a type 1 junction well (preferred) from the electrical service pedestal (refer to DeIDOT's Standard Construction Detail T-17) into the cabinet base.

Typical conduit access point designation should be as follows:

- Conduit 1: 120-volt cables (signal heads, remote services, etc.)
- Conduit 2: low voltage cables (detectors, opticom, etc.)
- Conduit 3: shall be for fiber optic applications.
- Conduit 4: shall be a dedicated spare.

7. Pole & Cabinet Base

Pole Base

DeIDOT utilizes a Pole Base, Type 4A with drop-in anchors to support conventional, aluminum pedestrian signal (pedestal) poles. A Pole Base, Type 4B with breakaway couplings is used to support ornamental steel pedestrian signal (pedestal) poles.

DeIDOT utilizes a Pole Base, Type 6B to support Rectangular Rapid Flashing Beacons (RRFB), Signal Ahead beacons, and Stop Ahead beacons.

For all designs with new traffic signals (i.e., mast arm uprights and strain poles), CCTV cameras, and/or vehicle detector poles, the signal designer should first consult DeIDOT's Geotechnical Engineer to determine if soil information is readily available for the project



location. If historical soil data is unavailable, the signal designer should submit a soil boring request form (see **Appendix O**). For Traffic-Only projects, all soil boring requests should go through the Traffic Systems Design Manager to DeIDOT's Materials & Research Manager, and Geotechnical Engineer. For all other projects, requests should be coordinated with the Project Manager and Group Engineer. Developers are responsible for obtaining soil borings and providing the Traffic Systems Design Manager with a signed and sealed report that includes the pole base recommendations. At a conventional four-legged intersection, the initial soil boring request should generally consist of two borings on diagonal corners or all affected corners, at the discretion of DeIDOT's Geotechnical Engineer. The anticipated project cost associated with soil borings is about \$10,000 per intersection, which the signal designer should include in preliminary engineering estimates and developer funding requests.

Following the soil analysis, DeIDOT's Geotechnical Engineer will recommend one of twelve soil condition "cases" for each pole base location for the signal designer to utilize as shown in **Table IV-5**.



Table IV-5 Pole Base Type Selection for Varying Soil Condition												
	"Poor" Soil Conditions						"Medium" Soil Conditions					
	Case 1 Sand over sand	Case 2 Sand over clay	Case 3 Sand over rock	Case 4 Clay over sand	Case 5 Clay over clay	Case 6 Clay over rock	Case 7 Sand over sand	Case 8 Sand over clay	Case 9 Sand over rock	Case 10 Clay over sand	Case 11 Clay over clay	Case 12 Clay over rock
Up to 40-ft mast arm	3A	3C	3	3B	*	3	3A	3A	3	3A	3A	3
40-ft to 60-ft mast arm	3B	3C	3	3C	*	3A	3A	3B	3	3A	3B	3
70-ft to 90-ft mast arm	3B	3C	3A	3C	*	3A	3A	3B	3	3A	3B	3
75-ft camera pole	3	3A	3	3A	3C	3	3	3	3	3	3	3
40-ft detector pole	3	3B	3	3B	3C	3	3	3	3	3	3	3
32-ft strain pole	3C	*	3A	3C	*	3B	3B	3C	3A	3B	3C	3A
37-ft stain pole	3C	*	3A	3C	*	3A	3B	3C	3A	3B	3C	3A

* Consultation with DelDOT's Geotechnical and Bridge Sections is required

In some cases, it may be necessary to also calculate the dead load for signal heads on mast arm or span wire before selecting the appropriate pole base. The signal designer shall refer to DelDOT's Bridge Design Manual. For additional resources, refer to the AASHTO LRFD Specification for Structural Supports for Highway Signs, Luminaires, and Traffic Signals for guidance.

Type 3, 3A, 3B and 3C pole bases shall have two (2) 3" Schedule 80 PVC conduit elbows with one providing a connection from the pole base to the nearest junction well and the other being capped, unless otherwise required. Type 4A and 4B pole bases shall have one (1) 2.5" Schedule 80 PVC conduit elbow connecting to the nearest junction well. All new signal pole bases shall tie directly into a junction well (unless otherwise approved by a Traffic Systems



Design representative). No signal pole shall have direct access to the signal cabinet unless the cabinet is directly mounted to the pole.

Type 3C pole bases require specialized foundation drilling equipment and unique mobilization. DelDOT's Traffic Construction Section should be consulted in advance of the construction handoff to review constructability and determine a project-specific cost.

Cabinet Base

There are four common cabinet base types used by DelDOT Traffic.

- Cabinet Base Type P – Signal, Lighting
- Cabinet Base Type F – Fiber
- Cabinet Base Type M – Intersection Lighting
- Cabinet Base Type P/R – Interchange Lighting

Refer to DelDOT's Standard Construction Detail T-4 for additional information. Any modification to the construction detail must be pre-approved by the Chief of Traffic Engineering prior to installation.

8. Signing

Signing removal or improvements may be required in conjunction with a new or modified signal design project. All proposed or removed signs shall be in accordance with the DE MUTCD for proper application and installation. Signs typically installed as part of a signal design include overhead regulatory and street name signs, signal ahead (W3-3) signs with advance street name plaques (W16-8P or W16-8aP), and/or other lane control, regulatory and warning signs as part of the signal design.

a. Overhead

All new and significantly retrofitted traffic control signals should include overhead street name signs (SNS). All SNS's on mast arms and span wires should have the following characteristics:

- Be dual-sided (except for one-way streets)
- Be hung below the span wire or mast arm
- Have a maximum width of 120 inches (10 feet)
- Have an initial upper-case height of 8" and lower-case height of 6", Highway Gothic D lettering. If the legend does not fit within 120 inches, use narrow letter kerning to fit the legend on the panel before downsizing the letter height by 0.5" increments.



- Have 17' minimum clearance from the roadway surface to the bottom of the sign
- Be installed only when the angle of the mast arm or span wire perpendicular to the direction of travel is less than 30 degrees.

Additionally:

- Overhead SNS may incorporate a route shield when the roadway meets the conditions set out in the DE MUTCD Section 2D.43 paragraph 02.
- Should match County 911 Center's official street name.
- Overhead SNS with two lines of lettering is not permitted.
- Single line overhead SNS should not be tethered.
- Regulatory signs mounted on mast arms should be rigidly mounted to the mast arm (not hanging).
- Span-mounted signs will not be tethered unless special circumstances, such as size dictate.

The combination of possible geometric intersection designs and signal designs makes it impractical to develop a specific policy that will show exactly where every sign should be located. For additional guidance refer to DelDOT's guidance memo on Overhead Street Signs Mounted on Traffic Signals in **Appendix P**.

b. Ground Mounted

An advance SIGNAL AHEAD (W3-3) sign with advanced street name plaques (W16-8P or W16-8aP) shall be installed for all approaches. For a new signal, a NEW (W16-15P) supplemental plaque shall be mounted above the Signal Ahead sign and remain in place for no longer than 6 months. Additionally, if an operational change is occurring, a NEW TRAFFIC PATTERN (W23-2P-DE) supplemental plaque shall be mounted below the Signal Ahead sign and remain in place for 90 days. Any additional required signs shall be displayed in accordance with the DE MUTCD.

Signs to be removed shall be clearly depicted in the plan sheet. For a stop-controlled intersection being converted to a signal, the "STOP" R1-1 and "STOP AHEAD" W3-1 shall be removed concurrently with the signal becoming operational.

9. Pavement Markings

A signal plan may require the installation or modification of existing pavement markings. All markings shall be designed in accordance with the DE MUTCD and may include crosswalks, stop lines, message/arrow markings, lane lines, channelizing and auxiliary lines, and edge lines. All new pavement markings shall be designed and detailed to a point where they can



be transitioned into the existing markings. All proposed markings shall be identified and quantified on the plans in accordance with DelDOT CADD standards. Quantities should be rounded up to the next 10-foot increment for estimating purposes. Removal of existing markings that conflict with new markings shall also be identified on the plans and quantified.

10. Maintenance of Traffic

The Traffic Designer needs to determine the maintenance of traffic (MOT) setups required to construct the project. Typical MOT requirements can be found in Chapter 6 of the DE MUTCD, primarily utilizing typical applications. Coordination with the Traffic Safety Section shall occur during the design process to determine allowable lane closure hours, pedestrian access, and any additional MOT requirements. If signal projects are part of capital projects, pavement rehabilitation projects, or developer projects, the signal construction MOT will fall under the overall project MOT and the Designer should coordinate with the project team developing the Transportation Management Plan (TMP).

The cost estimates prepared for Traffic-led projects should include all MOT items. Time restrictions, night work requirements, MOT checklist, and pedestrian access should be denoted on the plan and in the handoff form. For capital projects, pavement rehabilitation projects, and developer projects, the time restrictions set for the main contractor will typically also apply to the Traffic contractor.

11. Timesheet

The Designer should prepare and submit a draft timesheet to the TMC with the final plan set (the Traffic Systems Design representative is responsible for submitting the timesheet package to the TMC for developer's projects). The TMC is then responsible for finalizing the timesheet and obtaining the necessary signatures. Additional information related to preparing the timesheet can be found in Chapter IV-E of this Manual and **Appendix Z**.

The following information should be submitted to the TMC along with the draft timesheet:

1. A full-size signal plan with the official County 911 Center's street names. Historic intersection names should be denoted in parentheses where necessary.
2. Plan with critical movements showing Ws and Ds
3. Photographs documenting the posted speed limits on all approaches
4. Crosswalk distances*
5. Approach grades
6. Additional support material, as needed



**Note: Crosswalk distances can be shown in the plan view on the signal plan or in a separate document that details either or both of those plan elements.*

One copy of the latest version of the timesheet should be placed in the signal cabinet. Other copies should also be retained by the TMC and the District office.

12. Supplemental Equipment

In most cases, the design elements outlined above comprise all elements required for a complete signal design. However, in special circumstances, supplemental equipment may be required (such as HIBs, cameras, etc.) All supplemental equipment included in the final traffic signal design plans should be approved by the Traffic Systems Design Engineer before being included in the plans.

Separate ITS devices, such as cameras, wireless equipment, or Bluetooth readers may also be included in a signal design project. The design of these elements is covered later in this Manual in Chapter V.

13. Traffic Statement

DelDOT Traffic is responsible for developing the engineer's estimate for stand-alone Traffic Section Projects. For In-House Capital Projects, DelDOT Traffic will develop the Traffic Statement. For Consultant-led Capital Projects, and/or Developer / Subdivision Projects DelDOT Traffic will review and provide comments on the consultant-developed Traffic Statement. The Traffic Statement compiles an overall cost for all signal, signing, ITS, and lighting work to be completed as part of the project by either the on-call traffic and/or general contractor work. Each discipline is broken down into the following breakout sections:

Project Contractor Items – These are items associated with Capital Projects (i.e., bid items) or Developer / Subdivision Projects only. These are items or tasks the general contractor would perform as part of his required work for signal and ITS associated with the overall contract. The estimate should include the supply and installation and/or removal of roadway signing associated with the project, and furnishing, installing and testing of roadway and highway lighting systems.

Traffic Contractor Items – As part of Capital Projects or Developer / Subdivision Projects, these items would cover the cost of providing, installing, and removing of traffic-related equipment by DelDOT Traffic's on-call contractor. This cost would be associated with all the



wiring, connection, and integration required for signal and ITS work required under the scope of the project.

As part of Traffic Section Projects, these items would cover the cost of providing, installing, and removing traffic-related equipment, along with the cost to complete all underground work for signal and ITS projects. Also included would be the installation and/or removal of roadway signs associated with the project and the installation of all roadway lighting systems.

Traffic Supply Items – These are items to be supplied by DelDOT Traffic for all types of projects.

Unit Cost - The cost for contractor items is determined as part of the overall bid of the contract. For the engineer's estimated item cost, the designer shall determine the unit cost based on the latest DelDOT price index or historical data. Traffic contractor and supply item costs are based on agreed-upon on-call contractor prices.

Quantity Take-off - Many items are directly measured or counted as an actual number, such as junction wells, pole bases, poles, signal indications, cabinets, controllers, and devices. For other items, the following are the standard practices for quantity take-off:

Conduit – Use the total measured point-to-point in plan view. If additional footage is needed due to grade or elevation change, it should be denoted on the plan in the conduit run schedule.

Cable – Use the total measured quantity from all required underground pathway and pole height, mast arm length, and span wire distance to the underground pathway plus 10% to account for the excess required in junction wells, pole foundations, slack, and connections at the cabinet, and splices points.

Signs – Cost for each sign shall be provided, using the latest cost breakdown for signing.

Test Pit Excavation – Use one cubic yard for every two pole foundations.

Pavement Markings – Measure the actual quantity rounding to the next 10-foot increment for quantities under 150 feet or to the next 50-foot increment for quantities greater the 150 feet.



E. Signal Timing & Phasing

This chapter of the Traffic Design Manual discusses fundamental concepts and techniques involved in calculating the initial timing for various types of signal control. The focus of this chapter is on timing parameters related to design issues (phasing, loop placement, etc.) and basic signal timing considerations (yellow clearance interval, all-red, etc.) This chapter is not intended to address detailed timing practices, philosophy, etc.

In the past, signal timing was generally considered an operational responsibility rather than a part of the design activities. However, developing a recommended initial signal timing plan is an important design responsibility. Before a new signal can be activated for operation, a basic timing program must be established. Additionally, signal timing assumptions establish design details such as the number, type, and position of signal heads. Once a signal is constructed, signal timings should be reviewed for adequacy and updated as necessary to meet current demands.

The timing strategies that may be applied are a function of the type and capacity of the controller and the operational (traffic) requirements of the intersection. Pre-timed and actuated controllers are timed differently because of the inherent differences in operational philosophy and functional characteristics. Timing strategies also differ for isolated intersections, intersections along an arterial, and intersections within a system network.

The timing parameters for new or improved signalized intersections are frequently based on timing settings that have proved effective for similar types of intersections, traffic conditions, and equipment. These timing settings are implemented, and traffic flow is observed after the signal is activated. If, after the traffic has stabilized, excessive stops or delays occur, the timing is adjusted accordingly, and the rationale documented.

1. General

The functional objective of signal timing is to alternate the right of way among the various traffic and pedestrian movements in such a way as to:

- Provide for the orderly movement of traffic
- Minimize average delay to vehicles and pedestrians
- Reduce the potential for crash-producing conflicts
- Maximize the capacity of each intersection approach
- Maximize bandwidth on signalized arterials

Unfortunately, these desirable attributes are generally not compatible. For example, using as few phases as possible and the shortest practical cycle length may maximize approach capacity and minimize delay, while using multiple phases and longer cycles may reduce the number of conflict points and therefore improve safety. Accordingly, it is necessary to



exercise engineering judgment to achieve the best possible compromise among these objectives.

2. Timing Parameters

This section of the Traffic Design Manual describes the calculations required to determine appropriate values for various timing parameters, including cycle length, phase length, yellow change interval, and clearance (all-red) time. Before these calculations are presented, the following definitions of common terms related to signal timing are presented:

- **Cycle:** One complete sequence of signal indications (phases).
- **Phase:** That part of a signal cycle allocated to any combination of one or more traffic movements simultaneously receiving the right of way during one or more intervals.
- **Interval:** A discrete portion of the signal cycle during which the signal indications remain unchanged.
- **Offset:** The time difference (in seconds or in percent of the cycle length) between the start of the green indication at one intersection as related to the start of the green indication at another intersection or from the system time base (for signals on system).
- **Split:** The percentage of a cycle length allocated to each of the various phases in a signal sequence.

a. Cycle Length

The time required to complete a prescribed sequence of phases is known as the cycle length. For isolated, actuated intersections, cycle length varies from cycle to cycle based on traffic demand and signal timing parameters. For coordinated intersections, a background cycle length is used to achieve consistent operation between consecutive intersections. DelDOT typically uses a cycle length of 60 to 180 seconds. A shorter cycle length is typically used at low-volume rural intersections while a longer cycle length is typically used at intersections with heavy volumes on multiple approaches.

Selecting a cycle length is an iterative process that is initially performed during the second step of the critical movement summation (CMS) analysis (see **Appendix I**) or using Synchro models. CMS analysis focuses on “raw” intersection capacity, that is, the ability of an intersection to serve the demand for given lane configurations and signal phasing. This analysis is a fundamental tool for calculating green times and evaluating signal phasing schemes because it identifies movements that are “critical” to the signal



operations. Specifically, the results provide a baseline for determining signal timing parameters such as splits and cycle length.

According to ITE's *Traffic Signal Timing Manual*, "The amount of time in an hour is fixed, as is the fact that two vehicles (or a vehicle and a pedestrian) cannot safely occupy the same space at the same time. Critical movement analysis identifies the set of movements that cannot time concurrently and require the most time to serve demand." Additionally, CMS analysis incorporates the following basic assumptions for intersection geometrics and traffic flow:

- Lane widths and grades on the intersection approaches are "typical." No adjustments are made for specific widths or grades.
- Adjustments are not made for the specific composition of traffic. The proportion of trucks, motorcycles, bicycles, and buses does not affect analysis results.
- Pedestrians do not conflict with turning vehicles.
- Right-turning and left-turning vehicles discharge through the intersection at the same rate as through vehicles.
- Traffic does not equally distribute amongst multiple lanes on an approach.

Additional information regarding DelDOT's specific CMS procedures and guidelines can be found in Figure CMS-4 (formerly Appendix P) of the *Critical Movement Summation (CMS) How-to-Guide* in DelDOT's *Development Coordination Manual*.

Synchro is a proprietary traffic analysis and optimization software that can be used to determine signal timing parameters, including cycle length and splits. Synchro inputs include lane configurations and traffic volumes, similar to CMS. However, Synchro also takes into account additional variables including:

- Grades
- Traffic composition
- Peak hour factors
- Pedestrian volumes
- Right-turning and left-turning vehicle discharge rates
- Type of signal control (pre-timed, actuated, coordinated, etc.)
- Signal phasing
- Vehicle clearance intervals
- Placement of signal detectors and other features



Although Synchro can be used to optimize cycle lengths and splits, users will need to input additional data compared to CMS.

b. Vehicle Clearance Interval

On March 2, 2020, ITE revised and publicized its Recommended Practice on Guidelines for Determining Traffic Signal Change and Clearance Intervals. These new guidelines recommend a new way to calculate change intervals for left-turn movements – the “extended kinematic equations” – which is theoretical and lacks collaborative peer reviews, field implementations, and research. A distinguished panel of industry leaders and subject matter experts are expressing concerns regarding the change interval length (7 seconds) for left turns, especially along higher-speed roads. Many local and state agencies are postponing the adoption of the revised Recommended Practice, pending resolution of the concerns of industry leaders and/or further research and reporting on the topic. DelDOT will continue to utilize the procedures described in this section, which are based on research and guidelines published in the former ITE Recommended Practice, NCHRP Reports, and ITE Journal articles.

The vehicle clearance interval (or “change period”) consists of a **yellow change interval** (section 4E.2.c) and a **red clearance interval** (“all-red time”) (section 4E.2.d). The function of the vehicle clearance interval is to warn traffic of an impending change in the right-of-way assignment and then provide time to safely allow conflicting movements to proceed. The engineer must take care not to use excessively long change intervals because of the loss in efficiency and capacity at the intersection. Similarly, if the clearance interval is too short, crashes may increase. The following two sections discuss the typical DelDOT methodology for calculating the yellow change interval and the red clearance interval. It should be noted that clearance intervals may be adjusted based on field conditions, crash problems, or if observed speeds along a corridor are found to differ from the vehicle speeds assumed in the calculations.

c. Yellow Change Interval

The yellow change interval is the interval following a steady green or flashing red arrow interval during which a steady yellow signal is displayed. The purpose of the yellow change interval is to warn traffic of an impending change in the right-of-way assignment. The DE MUTCD states that “the duration of the yellow change interval shall be determined using engineering practices.” The Institute of Transportation Engineers (ITE) recommended method for calculating the yellow change interval is:



$$YCI = t + \frac{V}{2(a + Gg)}$$

where:	YCI = yellow change interval (s)
	t = perception-reaction time (s)
	V = approach speed, (ft/s)
	a = deceleration rate (ft/s ²)
	G = gravitational acceleration (ft/s ²)
	g = approach grade (ft/ft)

Discussion of each of these variables is presented below:

Perception-Reaction Time (t)

A study of driver perception-reaction time was performed and incorporated into recommendations presented in *NCHRP Report 731: "Guidelines for Timing Yellow and All-Red Intervals at Signalized Intersections."* The results of the study showed that the average reaction time was 1.0 second and the 85th-percentile reaction time was 1.33 seconds and recommends the use of 1.0 second. DeIDOT has adopted a value of 1.2 seconds for all yellow change interval calculations, which is greater than the NCHRP Report 731 recommendation, but less than the 85th percentile.

Approach Speed (V)

The 85th-percentile approach speed is suggested as the conservative basis from which the yellow interval should be calculated. Because conducting speed studies at all signals is cumbersome, an accurate approximation of the 85th-percentile speed is required. *NCHRP Report 731* recommends using the posted speed limit on the approach to the signal plus a constant value of 7 mph. DeIDOT has adopted this recommendation, which was determined through extensive field data collection for the report.

Deceleration Rate (a)

For stopping sight distance and other roadway calculations, DeIDOT has adopted the AASHTO Green Book methodology for calculating deceleration rate, which recommends 11.2 ft/sec² as the comfortable deceleration rate. AASHTO Green Book noted studies that show most drivers decelerate at a rate greater than 14.8 ft/s² and 90 percent of all drivers decelerate at rates greater than 11.2 ft/s². These decelerations are within the driver's capability to stay within his or her lane and maintain steering control during the braking maneuver on wet surfaces. Studies conducted for *NCHRP Report 731* also found that this recommended value falls within the mean and 85th-percentile deceleration rates of actual drivers.



Gravitational Acceleration (G)

Acceleration due to gravity is a constant value of 32.2 ft/s².

Approach Grade (g)

Maximum approach downgrade *within the stopping sight distance* should be measured and included in the yellow change interval calculation. Any upgrade should not be included in the calculation. The stopping sight distance can be determined from Table 3-1 of the AASHTO Green Book.

Significant Figures and Rounding

When calculating the yellow change interval, the result is reported to two significant figures. The value implemented in the controller is rounded up to the next whole second. For example, if running the equation yields a calculation of 4.0488 – report to two significant figures (4.0), and no rounding is needed. If the equation yields a calculation of 4.0529 – report to two significant figures (4.1), and round up to the next whole second (5.0).

Left Turns and Split Phasing

Yellow change intervals for non-permissive left-turn movements should match the adjacent through movement on the same approach.

Other Requirements

Yellow change intervals for main-street movement pairs (phases 1, 2, 5, 6 as shown in **Figures IV-7 and IV-8**) should match in each direction. Side street movements may have different yellow change intervals. For example, if phase 2 required yellow is 4.0 seconds and phase 6 required yellow is 5.0 seconds, field-implemented yellow intervals should be 5.0 seconds for both phases 2 and 6 (typical main-street through movement phase numbers). If phase 4 required yellow is 3.0 seconds and phase 8 required yellow is 4.0 seconds, field-implemented yellow intervals can be 3.0 seconds for phase 4 and 4.0 seconds for phase 8. The maximum yellow change interval is 6.0 seconds.

d. Red Clearance Interval (All-Red)

The red clearance interval is the interval that follows the steady yellow interval during which a steady red signal is displayed to potentially conflicting traffic movements at an intersection. The purpose of the red clearance interval is to provide additional time before conflicting traffic movements are released. The DE MUTCD states that “when used, the duration of the red clearance interval shall be determined using engineering practices.”



The method selected by DeIDOT for timing red clearance intervals at signalized intersections is the one described in the *ITE Journal* article “A Rational Method for Setting All-Red Clearance Intervals” (Fitch, et. Al; February 2011). The proposed method calculates how long a vehicle legally entering the intersection at the end of the yellow change interval takes to clear the farthest conflict point with a conflicting vehicle legally entering the intersection at the beginning of the next green interval. The calculation can be summarized as follows:

$$RCI = t_c - t_{min}$$

where: RCI = red clearance interval (s)
 t_c = maximum clearance time (s)
 t_{min} = minimum conflicting time (s)

To complete the calculation, a “worst-case” conflict point must be identified for each movement. A conflict point is any point where the clearing vehicle’s path is crossed by the path of a conflicting movement. The “worst-case” conflict point, therefore, is the farthest conflict point from the stop line along the driving path of the clearing vehicle. **Figure IV-9** below depicts the “worst-case” conflict points for the through and left-turn movements at an example intersection.

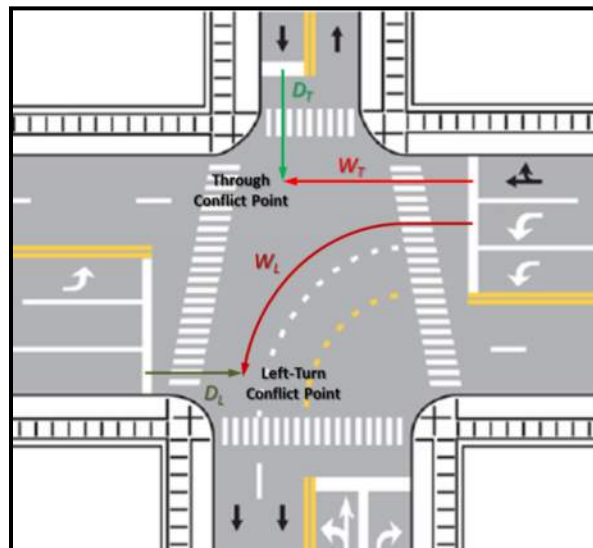

Figure IV-9. Intersection Conflict Points

Maximum Clearance Time (t_c)

A reasonable expectation for a signal timing policy is to account for drivers who enter the intersection on the last instant of the yellow indication because such behavior is both legal and commonly observed. The “worst-case” scenario is therefore presented by a



vehicle entering the intersection on the last moment of yellow change and traveling at the low end of the speed distribution because a slow vehicle will occupy the intersection longer than a faster one. The 10th-percentile speed is recommended. The 10th-percentile speed can be estimated by subtracting a differential speed value from the 85th-percentile speed, which is estimated as the posted speed limit plus 7 mph (see yellow change interval calculation) per *NCHRP Report 731*. The *ITE Journal* recommends subtracting 10 mph from the 85th-percentile speed for speeds 45 MPH and below and subtracting 15 mph for speeds above 45 mph, with a floor of 30 mph. **Table IV-6** below summarizes the estimated 10th-percentile speeds for each posted speed limit.

Posted Speed Limit (mph)	10 th Percentile Speed (mph)
25	25
30	30
35	32
40	32
45	37
50	42
55	47

Based on this estimate, the maximum clearance time is:

$$t_c = \frac{W}{1.47 \times S_{10}}$$

where: t_c = maximum clearance time (s)
 W = clearing width, stop line to conflict point (ft)
 S_{10} = 10th percentile speed (mph)

This time represents the latest time, following the end of the clearing phase's yellow, that a vehicle on that phase could be reasonably expected to occupy the conflict point.

Minimum Conflicting Time (t_{min})

A reasonable expectation for drivers seeing a red indication change to green is that they will simply accelerate into the intersection if no traffic is obviously in conflict. The critical "worst-case" combination scenario is observed when a vehicle approaches an intersection without coming to a complete stop as a red indication changes to green. If no other vehicle is stopped at the intersection as an impediment, then a realistic



expectation is that the driver of this vehicle should be decelerating at a rate that would allow a stop at the stop bar for the red (because the driver cannot know when a green indication will be displayed) but, upon seeing the green, will accelerate at a comfortable rate. This vehicle will exhibit a “rolling start” and will cross paths with traffic clearing the intersection sooner in time than if it had started from a complete stop at the intersection stop bar. While deceleration and acceleration rates can vary greatly, *ITE Journal* (Fitch, et. al) made a conservative assumption of -10 ft/s^2 deceleration and 15 ft/s^2 acceleration, which has been adopted by DelDOT. The minimum conflicting time calculation thus simplifies to:

$$t_{min} = 0.283\sqrt{D}$$

where: t_{min} = minimum conflicting time (s)
D = conflicting distance, stop line to conflict point (ft)

This time represents the minimum amount of time, following a new green light, for a driver to accelerate (at 15 ft/s^2) to a conflict point D feet beyond the stop bar, assuming that the driver had been decelerating at a rate (-10 ft/sec^2) that would have resulted in a safe stop at the stop bar.

Left Turns and Split Phasing

Red clearance intervals for non-permissive left-turn movements shall be calculated in the same manner as each through movement – determining a worst-case conflict point and measuring the two conflicting distances (W and D). The only change is the estimated 10th-percentile speed (S_{10}) used in the equation to calculate t_c is 20 mph as suggested by NCHRP Report 731 and *ITE* guidelines.

Minimum Red Clearance Interval

Due to a long historical precedent in Delaware of using 2.0 second all-red clearance intervals, and driver expectation of this standard value, DelDOT recommends a minimum red clearance interval of 2.0 seconds for all signalized movements.

Significant Figures and Rounding

When calculating the red clearance interval, the result is reported to two significant figures. The value implemented in the controller is rounded up to the next whole second. For example, if running the equation yields a calculation of 2.0497 – report to two significant figures (2.0), and no rounding is needed. If the equation yields a calculation of 2.0513 – report to two significant figures (2.1), and round up to the next whole second (3.0).



Other Requirements

Red clearance intervals for main-street through movements (phases 2 and 6 as shown in **Figures IV-7 and IV-8**) shall match in each direction. Side street movements may have different red clearance intervals. For example, if phase 2 required all-red is 2.0 seconds and phase 6 required all-red is 3.0 seconds, field-implemented all-red intervals shall be 3.0 seconds for both phases 2 and 6 (typical main-street through movement phase numbers). If phase 4 required all-red is 2.0 seconds and phase 8 required all-red is 3.0 seconds, field-implemented all-red intervals can be 2.0 seconds for phase 4 and 3.0 seconds for phase 8.

3. Phasing

The DE MUTCD defines a signal phase as the right-of-way, yellow change, and red clearance intervals in a cycle that is assigned to an independent traffic movement or combination of traffic movements. Signal phasing is the sequence of individual signal phases or combinations of signal phases within a cycle that defines the order in which various pedestrian and vehicular movements are assigned the right of way. This section of the *DeIDOT Traffic Design Manual* includes descriptions of the different possible phasing options and provides general guidance on selecting appropriate phasing. Refer to the DE MUTCD for additional rules for determining controller phasing, selecting allowable signal indication combinations for displays on an approach to a traffic control signal, and determining the order in which signal indications can be displayed.

a. NEMA Phasing

Signal phasing at most intersections in Delaware should use the standard National Electrical Manufacturers Association (NEMA) ring-and-barrier structure. This structure organizes phases to prohibit conflicting movements (e.g., eastbound and southbound through movements) from operating concurrently while allowing nonconflicting movements (e.g., northbound and southbound through movements) to operate together. In the phasing diagram, phases associated with dashed lines are compatible and may operate concurrently. Phases associated with solid lines are conflicting and will not operate concurrently.

If the side street phasing is split, the side streets use Phases 3 and 4 only. If the side streets run concurrently, phase 4 and 8 shall be utilized. At a "T" intersection, the side street is typically Phase 4.

The NEMA phasing diagram was presented earlier in this Manual as **Figure IV-7** in Chapter IV-D.5.



While the standard NEMA ring-and-barrier structure allows most of the signal phasing patterns in use in the State of Delaware to be achieved, there are some special cases where an alternative structure may be used, such as for five-leg intersections and some lead-lag operations.

b. Selecting Appropriate Phasing

The simplest form of phasing is a two-phase sequence in which NEMA Phases 2 and 6 run concurrently to allocate the right of way to the main street followed by NEMA Phases 4 and 8 running concurrently to transfer the right of way to the cross street. In this two-phase sequence, the major cross (through) movements are separated, but the left-turn movements must yield to opposing traffic, turning only when there is an adequate gap in traffic.

In determining the number of phases required at an intersection, the goals of safety and capacity may conflict. For example, in many situations, protected left-turn phases are safer for left-turning vehicles than protected-permitted left turns. However, the added phases may result in longer cycle lengths, reduced progression in systems and increased delay and percent of vehicles stopped. These factors adversely impact traffic performance, capacity, and fuel consumption, and may tend to reduce safety for all traffic by increasing rear-end crashes.

The following **general rules for acceptable intersection phasing** should be followed:

- The Main Street through movement should be phase 2 for North or East, and phase 6 for South or West.
- The Main Street left-turn movement should be phase 5 for North or East, and phase 1 for South or West.
- Side Street through movements should be phase 4 and phase 8.
- Side Street left-turn movements should be phase 3 and phase 7.
- For Split Phasing, the lower volume cross street approach should be phase 3 and the higher volume cross street approach should be phase 4.

c. Left Turn Treatment

An important consideration in developing an appropriate signal phasing plan is determining the left-turn phase type at the intersection. The most basic form of control for a four-legged intersection is “permissive only” control, which allows drivers to make left turns after yielding to conflicting traffic or pedestrians and provides no special protected interval for left turns. However, for most high-volume intersections, “permissive-only” left-turn phasing is generally not practical for major street movements.



Therefore, some type of “exclusive” (protected) control is typically provided once traffic volumes or the number of crashes at the intersection exceed established thresholds. The various types of left-turn treatments and the guidelines for selecting them are presented in the following section.

1.) Separate Left-Turn Lanes

Before considering the implementation of an exclusive left-turn phase, the designer should first consider the benefits of providing a separate left-turn lane while maintaining “permissive only” phasing. In most cases, intersections considered for signalization in Delaware should have at least two lanes on each approach, including separate left-turn lanes on the mainline. The lane configuration for the side street approaches can vary, but typically at least two lanes should be provided.

2.) Left-Turn Phasing

The type of left-turn phasing operation chosen for a signalized intersection is one of the most critical traffic signal design and operational issues considered. There is typically a trade-off between safety and efficiency in this decision. **Figure IV-10**, which DelDOT adapted from FHWA’s Signal Timing Manual, provides guidelines for determining the appropriate left turn treatment. The list on the pages following **Figure IV-10**, in generic terms, is in order of least delay/least restrictive to most delay/most restrictive for left-turning traffic. Note that for any traffic movement with any type of signal operation, drivers are required to cautiously enter the intersection, and must yield to other vehicles and pedestrians who are lawfully within the intersection.

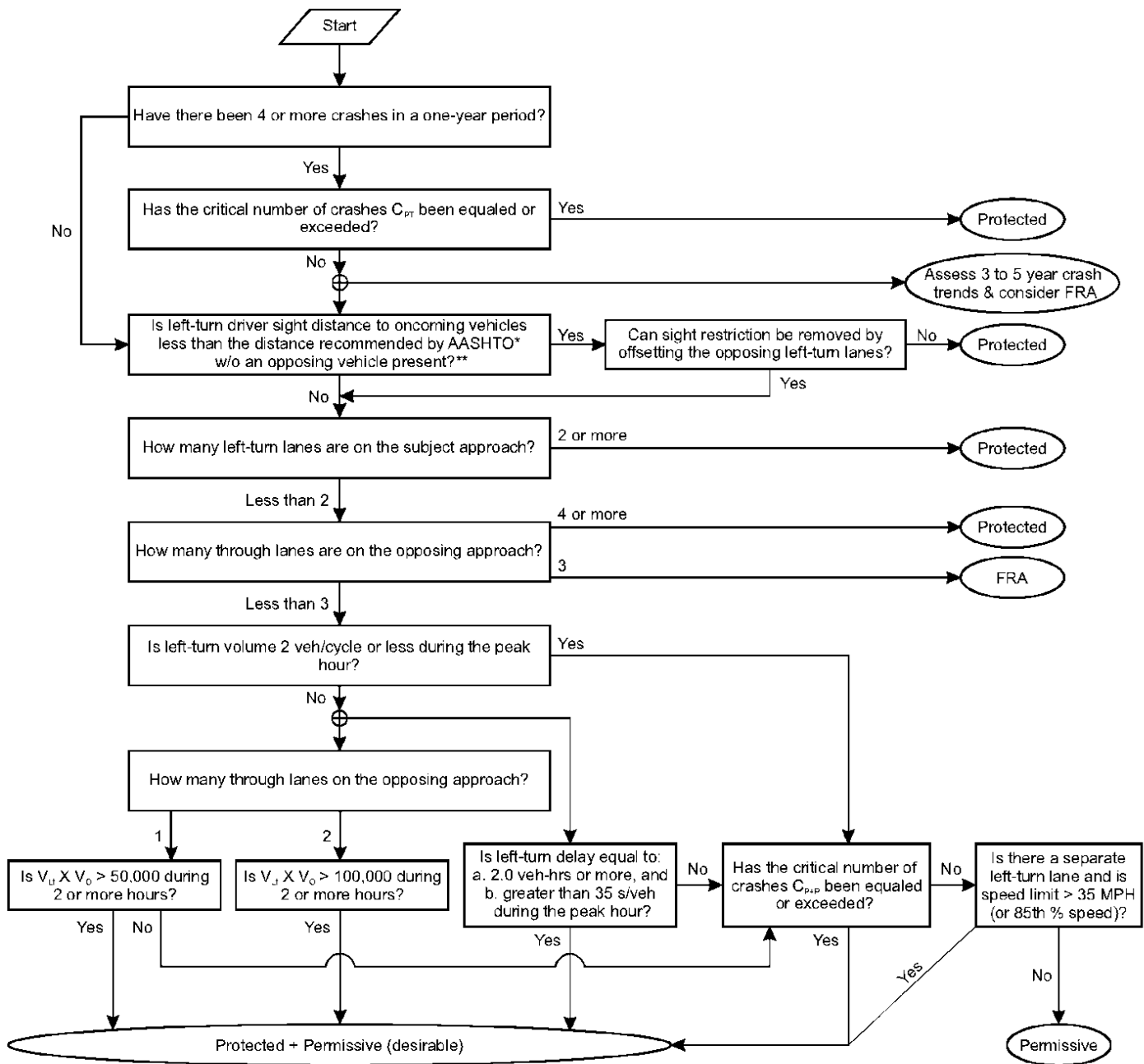

*AASHTO, *A Policy on Geometric Design of Highways and Streets*, 2011 (or current).
 Chapter 9, 9.5.3 Intersection Control, Case F - Left Turn From the Major Road.
 Calculated based on Equation 9-1 and Table 9-13, adjusted for number of lanes, as needed.

**If left-turn driver sight distance is temporarily obstructed by an opposing left-turning vehicle and consequently temporarily less than AASHTO recommendations, consideration should be given to the obstruction's frequency and the potential for and severity of crashes (e.g., consider opposing left turn phasing, opposing through speeds and volumes).

Variables:

V_L = left-turn volume on the subject approach, veh/h
 V_O = through plus right-turn volume on the approach opposing the subject left-turn movement, veh/h

Source:
 Adapted from FHWA's
 Signal Timing Manual

Number of Left-turn Movements on Subject Road	Period During Which Crashes are Considered (years)	Critical Left-Turn-Related Crash Count	
		When Considering Protected-only, C_{PT} (crashes/period)	When Considering Prot.+Perm., C_{PT+P} (crashes/period)
One	1	6	4
One	2	11	6
One	3	14	7
Both	1	11	6
Both	2	18	9
Both	3	26	13

Figure IV-10. Guidelines for Determining Left-Turn Lane Signal Phasing Treatment



Permissive



This type of operation never provides a separate left-turn arrow. Drivers turn left on a green ball when they can find a gap in opposing traffic. This type of operation is often used on relatively low-volume side streets, and sometimes in urban areas with relatively low speeds and low left-turning volumes. Specifically, permissive left-turn phasing for DelDOT's signals should only be used when there is a single left-turn lane opposed by one (1) or two (2) through lanes. Permissive left-turn phasing should also only be implemented if the sight distance to oncoming traffic is greater than the minimum distances recommended by AASHTO, and the volume, speed, and crash thresholds are below those established in **Figure IV-10**.

Protected-Permissive

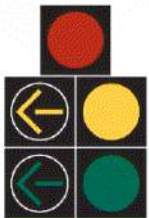

This type of operation is typically implemented in Delaware with the "doghouse" signal head. Normally a left-turn green arrow is displayed first (protected part of phase), followed by a yellow left-turn arrow, and finally a green ball (permitted part of phase). Protected-Permissive phasing for DelDOT's signals should only be used when there is a single left turn lane that is opposed by one (1) or two (2) through lanes. Protected-permissive left-turn phasing should also only be implemented if the sight distance to oncoming traffic is longer than the minimum distances recommended by AASHTO (see **Figure IV-10**). **Figure IV-10** provides specific volume and crash thresholds, one or more of which should be met to implement protected-permissive phasing.

Special Protected-Permitted (Flashing Red Arrow)

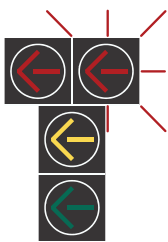

Protected-permitted operation with a flashing red arrow has been implemented at numerous signalized intersections in Delaware with great success. Normally, a left-turn green arrow is displayed first (the protected phase), followed by a yellow arrow, then a red arrow, and finally a flashing red arrow (the permitted phase). Legally, drivers are required to completely stop and then proceed during the flashing red arrow interval. DelDOT can adjust the amount of time of the solid red arrow period prior to the flashing red arrow phase based on the conditions at the intersection. This type of left-turn operation can be operated with variable, time-of-day settings to accommodate left turn demand (or lack thereof) in order to reduce vehicular delay.



Protected-Only



Protected-only left-turn phasing allows left-turning vehicles to proceed only on a green arrow indication, eliminating the need for motorists to judge gaps in traffic in order to execute their turn. This type of left-turn operation is often implemented on multilane and/or divided highways with both heavy left-turning and opposing through traffic, and also where there has been a pattern of left-turn crashes. Protected-only left turn phasing shall be used on all approaches with more than one left turn lane. Vehicle speeds, sight distance restrictions, and motorist expectancy are additional criteria that should be taken into consideration when evaluating the need for protected-only operations, according to the guidelines presented in **Figure IV-10**.

Split Phasing

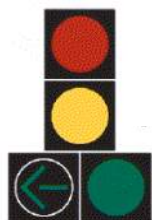

This is a form of protected-only operation where all movements on an approach get green, yellow, and red indications with no opposing traffic. This type of operation is occasionally used on side streets with shared left/through lanes and relatively heavy left-turn volumes. Depending on the number/type of lanes and traffic volumes, this type of operation may be optimal for side street movements, but often requires additional time which must be taken away from main street movements. For more information, refer to Chapter IV-E.3.d of this Manual.

3.) Lead / Lag Lefts

There are two primary alternatives for the timing of a protected-only left-turn phase in a cycle sequence. When the protected-only left-turn phase precedes the through movement in the same direction, it is called “lead” left. When the protected-only left-turn phase follows the through movement in the same direction, it is called “lag” left. While used on an infrequent basis in Delaware, lag lefts can be combined with a lead left in the opposing direction. This sequence is commonly called “lead-lag” phase sequencing. While these different left-turn sequences have advantages and disadvantages, the most common practice in Delaware is to provide lead left-turn phases on all approaches.

In a small number of situations, a lag left-turn phase may be beneficial. These include:

- Where both opposing left-turn lanes are protected-only and there are left-turn storage bay issues, particularly where the left-turn lane may be frequently blocked by queues in the through lanes.



- Where both opposing left-turn lanes are protected-only and a lag left turn benefits bandwidth
- Where there are no left turn lanes and a relatively even number of left turns in both directions.
- Where both opposing left-turn lanes are protected-only and the AASHTO Green Book minimum clear distance of 10 feet between the turning vehicles is not feasible.

While lag left turn phasing may improve operations, care should be taken to avoid the “yellow trap”, as discussed in the following section.

4.) Yellow (Left-Turn) Trap

The combination of a permissive left-turn phase and an opposing lag phase can lead to a situation commonly referred to as the “yellow trap.” As shown in **Figure IV-11** on the following page.

If this scenario is permitted, a left-turning vehicle, present at the end of the through phase (i.e., still awaiting a gap when the “yellow ball” is displayed), may incorrectly presume that the opposing through phase also is ending. When the signal turns red, the left-turning vehicle may get “trapped” in the intersection or attempt to complete the turn into oncoming traffic.

To mitigate the yellow trap phenomenon either created by a preset signal sequence (e.g., lead/lag protected/permissive left-turn phasing) or by unique cycle-by-cycle traffic characteristics, such as low side-street demand or emergency vehicle preemption, DelDOT has developed yellow trap guidelines for over 20 scenarios (see **Appendix Q**). Based on these guidelines, DelDOT’s most common yellow trap countermeasure is to program a protected/permissive controller with a special sequence to omit left-turn calls during the adjacent through phase; however, there are also warning sign options per Sections 2C.48 and 4D.05 of the DE MUTCD.

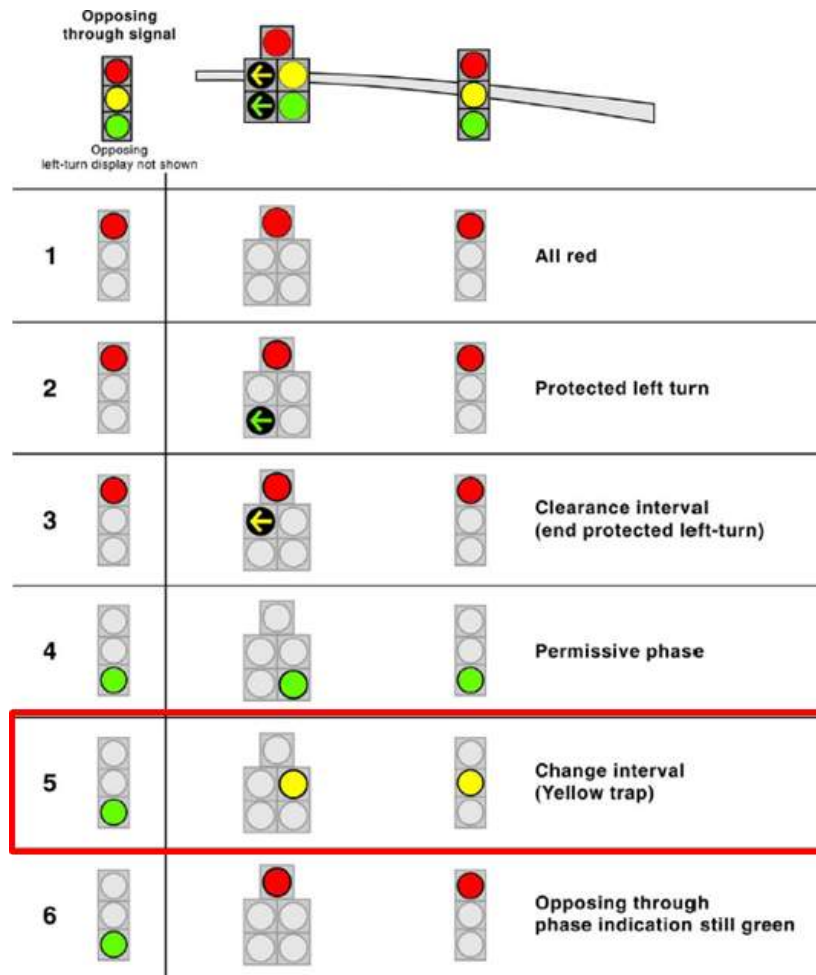

Source: FHWA's [Signalized Intersection Guide](#)

Figure IV-11. Yellow Trap with Protected/Permissive Left-Turn Phasing

5.) Flashing Red Arrow

DelDOT is one of the few agencies in the country that utilizes a flashing red arrow left turn phase. In 2008, DelDOT formally reviewed the safety and operational characteristics of all flashing red arrow intersections in Delaware. Some locations have been modified to protected-only operations due to moderate crash issues or concerns about intersection sight distances. An updated evaluation of all locations has been conducted twice since 2008, and DelDOT presently has a statewide assessment program to study both variable (time-of-day) and full-time flashing red arrow requests/designs.

With flashing red arrow (FRA) left-turn phasing, there is an opportunity to subsequently operate with “safer” protected-only left-turn phasing during specific times of day. Turning movement counts (and resulting queues and delays), crash



history, and left-turning sight distance (both with and without queued opposing traffic present) should be evaluated further when considering a time-of-day option, where vehicles are allowed to turn after stopping. A relatively common implementation of time-of-day FRA phasing utilizes protected-only phasing during relatively high-crash, high-volume time periods (e.g., weekday AM through PM peaks) and then operates with FRA during all other “off-peak” periods, including 24/7 on weekends.

Given the relatively successful use of flashing red arrows in Delaware, DelDOT intends to ensure that all existing locations will remain compliant with revised federal guidelines and may install them at additional intersections after reviewing the guidelines for determining left turn lane signal phasing treatments (see **Figure IV-10**). For additional discussion regarding the use of a flashing red arrow compared to other left-turn phasing treatments, refer to Chapter IV-E.3.c.2 of this Manual.

For additional information regarding signal indications for permissive mode left turns, including flashing arrows, refer to Section 4D.18 of the DE MUTCD.

6.) Flashing Yellow Arrow

Flashing yellow arrow has not been fully adopted as a left turn treatment by DelDOT. The use of flashing yellow signal indications should be approved by the Chief of Traffic Engineering.

7.) Other

Refer to the current version of the DE MUTCD, Section 4D.17, for guidance on additional acceptable left-turn treatments that could be considered.

d. Split Phasing

Split phasing consists of having two opposing approaches run consecutively rather than concurrently (i.e., all movements originating from the west followed by all movements originating from the east). **Split phasing should be used infrequently because a more-efficient conventional phasing plan can usually be found.** However, the following conditions could indicate that split phasing might be an appropriate design choice:

- There is a need to accommodate multiple turn lanes on an approach, but adequate width is not available to provide separate lanes so a shared through/left lane is required. An operational analysis should be performed to ensure this option is superior compared to a single turn lane option under various phasing scenarios.



- The left-turn lane volumes on two opposing approaches are approximately equal to the through traffic lane volumes on the same approach but the total approach volumes are significantly different on the two approaches. Under these somewhat unusual conditions, split phasing may prove to be more efficient than conventional phasing.
- A pair of opposing approaches is physically offset such that the opposing left turns could not proceed simultaneously or a permissive left turn could not be expected to yield to the opposing through movement.
- The angle of the intersection is such that the paths of opposing left turns of errant turning motorists could easily overlap.
- The safety experience indicates an unusual number of crashes (usually sideswipes or head-on crashes) involving opposing left turns. This may be a result of unusual geometric conditions that impede the visibility of opposing traffic.
- A pair of opposing approaches each has only a single lane available to accommodate all movements and the left turns are heavy enough to require a protected phase.
- One of the two opposing approaches has heavy demand and the other has minimal demand. Under this condition, the signal phase for the minimal approach would be skipped frequently and the heavy approach would function essentially as the stem of a “T” intersection. For this condition, it is important that the signal be designed with actuation on the minor volume approach and the controller be programmed to skip the phase entirely if no vehicles are present.

For additional discussion regarding the use of split phasing compared to other left-turn phasing treatments, refer to Chapter IV-E.3.c.2 of this Manual.

4. Types of Control

Traffic control signals operate in either pre-timed or actuated mode. Pre-timed signals operate with fixed cycle lengths and green splits. Actuated signals vary the amount of green time allocated to each phase based on traffic demand. Either type may be used in uncoordinated (isolated) or coordinated operations (see Chapter IV-E.5 of this Manual). There is no universal "best" method of determining the optimum type of control for a given local intersection. Each type of control has its unique advantages and disadvantages.

- Pre-timed controls may feature multiple timing plans, with different cycle, split, and offset values for different periods of the day. The timing plans are generally established based on historic and/or anticipated traffic demand, and the signal splits and cycle lengths do not change as a result of real-time traffic flow. When used in a



system, adjacent intersections operate on the same signal cycle and have fixed controller offsets. Because pre-timed control does not recognize or accommodate short-term fluctuations in traffic demand, it can cause excessive delays to vehicles and pedestrians where a high degree of variability in the traffic flows exists. DelDOT rarely installs or operates signals with pre-timed control. Rather, pre-timed control is typically applied in urban grid networks, and/or at locations where grid coordination is desired.

- Actuated control provides variable lengths of green timing for phases. The time for each movement depends on the characteristics of the intersection and timing parameters. Actuated control does not rely on a fixed cycle length unless the intersection is in a coordinated system or under adaptive control. This type of control assigns the right of way on the basis of actual traffic conditions (demand) within given limitations.

- 1) **Fully-actuated** (“system free”) control requires detectors for all phases, with each phase timed according to preset timing parameters.

In a fully actuated application, the controller unit operates on continuously variable cycle lengths. For all phases, the number of vehicles detected on the various controlled approaches determines green times. Fully actuated operation is generally used when the intersection operates independently and where demands on all approaches vary throughout the day.

- 2) **Actuated-coordinated** control requires detectors on the minor-street approach and main street left-turn lanes, and is especially effective in systems and at intersections where the major street has a relatively uniform flow and the minor street has low volumes with random peaks.

The non-actuated phase is the phase that is coordinated with adjacent intersections, whereas actuated phases are allowed to respond to detected demand.

With the actuated-coordinated control application, one phase (usually the major street) operates in the non-actuated mode. Vehicular and/or pedestrian detection is required on the phase(s) that is (are) actuated. This type of operation is often used where the controller is incorporated into a coordinated system. The non-actuated phase is the phase that is coordinated with adjacent intersections, whereas actuated phases are allowed to respond to detected demand.



a. Selection Considerations

From a signal timing perspective, selecting the best type of control for a location requires full knowledge of local conditions, but, in general, can be based on:

- Variations in peak and average hourly traffic volumes on the major approaches
- Variations in morning and afternoon hourly volumes
- Percentage of volumes on the minor approaches
- Usage by large vehicles, pedestrians, and bicycles

1.) Volume Characteristics

The volume of vehicle traffic on the minor approaches will frequently indicate the type of control needed. For example, if traffic on the minor approach arrives at the intersection in low volumes and/or with random arrival patterns at a steady rate for most hours of the day, but the mainline volume is typically more uniform, semi-actuated, or pre-timed control usually operates effectively.

In general practice, the rule of thumb is: for predictable traffic, use semi-actuated; for unpredictable traffic, use fully actuated control. Another form of this general rule can be stated in terms of the warrant satisfied. The minimum vehicular warrant (Warrant 1) requires a steady volume for 8 hours on the minor approach, thus suggesting semi-actuated control. Interruption of continuous traffic (Warrant 2) usually involves the sporadic arrival of traffic on the minor approaches, thus indicating fully actuated control.

2.) Other Characteristics

In addition to the volume consideration discussed above, other factors may exert an influence on this determination. Specifically, if the intersection is part of a traffic control system, the type of control selected must be compatible with the system. Maintenance capabilities may also influence the selection in that the more advanced control hardware requires a much higher level of maintenance expertise.

b. Elements of Control

1.) Pre-timed Control

There are several fundamental aspects of developing timing settings for signal control. The essential elements include:

- Number of timing plans



- Phase change intervals (yellow change plus all-red clearance)
- Pedestrian timing requirements (including the decision on whether or not to use pedestrian indications)
- Cycle length calculations
- Split calculations
- Flashing operation

To function effectively, signal operations must take into account a number of local intersection variables and hardware characteristics. It is difficult to establish comprehensive guidelines to fit all possible situations. In many situations, it is desirable to monitor the initial operations and adjust the timing settings to reflect the unique character of the intersection and traffic flow. The following discussion is intended to provide a conventional approach to establishing initial timing settings and reasonable ranges of values for the various parameters.

“Time-of-Day” Signal Timing Plans

A timing plan may be defined as a unique combination of cycle length (commonly ranging from 60 to 180 seconds), split, and, in system operations, offset. Most controllers today have the capability of numerous timing plans. Timing plans may differ by phase length, cycle length offset, phase arrangement, or any combination thereof.

Traffic demand at the intersection is the critical determinant of the number of timing plans required. For example, for a two-phase intersection that is heavily loaded on one phase during the morning peak, heavily loaded on the opposite phase during the evening peak, and lightly loaded on both phases during the remainder of the day, it is obvious that three plans would be required. Traffic demand patterns typical of a majority of locations may be categorized as:

- A.M. peak period
- Average day (midday) period
- P.M. peak period
- Night (low-flow) period
- Weekend or special function periods

DelDOT’s time-of-day patterns (i.e., “coordination data”) are typically programmed in the TMC’s signal system database and operate based on a time-based coordination (TBC) schedule. Each individual signal pattern should be generated using CMS analysis



and the time-based data should be developed using hourly and diurnal traffic volume data, which is typically available via Traffic's signal system detection or Planning's automatic traffic recorders.

The most common method for implementing signal timing patterns is through time-of-day and day-of-week schedules, which change timing patterns at specific, predetermined time periods (e.g., AM, mid-day, and PM peak periods). When traffic conditions vary significantly within these time periods, or when traffic is inconsistent on a day-to-day basis, time-of-day schedules are not as effective in reducing delays and queues. Traffic-responsive operation is an alternative to time-of-day control. It uses vehicle detection to monitor real-time traffic conditions – volume (or headways) and density (or spacing) – to select a timing pattern that is best suited for the current traffic conditions.

Traffic-responsive systems use system detectors to monitor and control the signal system. The system detectors are capable of categorizing data based on the following functions:

- Congestion level – cycle length selection
- Major versus minor-street demand – split selection
- Arterial travel direction (inbound, outbound) – offset selection

Real-time traffic data is collected by system detectors, analyzed, and then compared to predefined data profiles for timing patterns with unique cycle lengths, splits, and offsets. When a profile match is identified, the corresponding timing pattern is implemented.

Because traffic-responsive systems are only capable of selecting timing parameters not modifying them, this type of operation still requires transportation professionals to determine timing patterns and develop a “library” that is best suited for varying traffic conditions.

There is a transition period along a signal system when timing plans change, and coordination is temporarily interrupted as the cycle length and/or offsets are adjusted. Therefore, the “sensitivity” of a traffic-responsive system should be considered when developing a selection matrix to avoid frequently changing timing plans.



2.) Basic Timing Parameters

Minimum Green Interval

The minimum green interval is the shortest time a called phase can receive a green indication. For main-street through phases, DelDOT typically utilizes a 10-second or 15-second minimum green time. For all other phases, a 5-second minimum green interval is often used.

Passage Time

The green time for an actuated phase can be extended via the passage interval (or extension/gap). For left-turn phases, DelDOT's general standardized value is 3-second passage time. Split side-street phases and all through phases typically utilize a 4-second passage interval.

Maximum Green Interval

The maximum green interval is the longest time a called phase can receive a green indication. For main-street through phases, DelDOT typically operates with a 60-second maximum green time. For side-street through or split phases, DelDOT typically defaults to a 30-second maximum green time and a 20-second maximum green interval is often used for left-turn phases. It should be noted that the maximum green interval may get overridden by system data when the signal operates as part of a coordinated system.

c. Controllers

DelDOT has standardized with NEMA-structured, dual-ring controllers that must be compatible with the current signal system at DelDOT's TMC.

Dual-ring controller unit: A controller unit containing two interlocking rings that are arranged to time in a preferred sequence and to allow concurrent timing of both rings, subject to the restraint of the barrier (compatibility line). The phases within the two timing rings shall be numbered as illustrated in **Figure IV-12**. It should be noted that DelDOT's typical signal controllers allow additional phases to be added, if needed, for special circumstances.

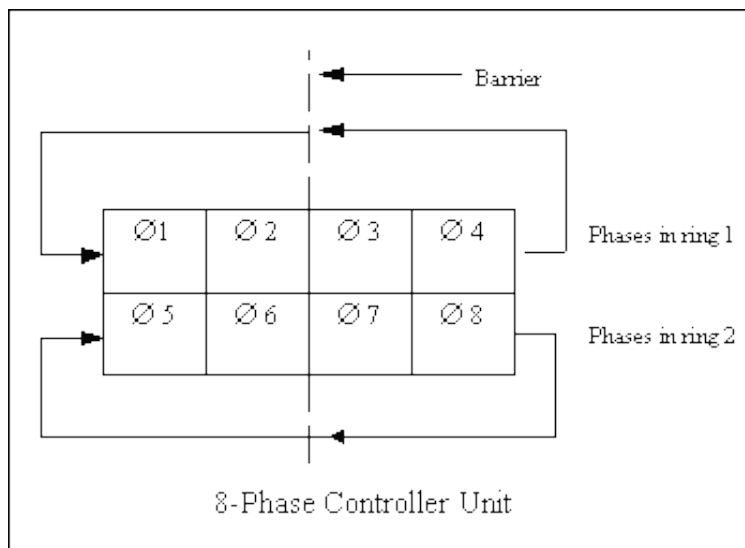

Figure IV-12. Sequence of Phases for Dual-Ring 8-Phase Controller Unit

Barrier (compatibility line): The Barrier is a reference point in the preferred sequence of a dual-ring controller unit at which both rings are interlocked. Current NEMA equipment has more than two barrier capability with two barriers as the NEMA standard. Two reference points or barriers assure that there will be no concurrent selection and timing of conflicting phases for traffic movement in different rings, as illustrated in Figure IV-12. Both rings cross the barrier simultaneously to select and time phases on the other side.

Dual entry: A mode of operation (in a dual-ring controller unit) in which one phase in each ring must be in service. If a call does not exist in a ring when it crosses the barrier, a phase is selected in that ring to be activated by the controller unit in a predetermined manner. For example, referring to **Figure IV-12**, in the absence of calls on Phases 7 and 8, Phase 2 and Phase 6 terminate to service a call on Phase 3. Programming determines whether Phase 7 or Phase 8 will be selected and timed concurrent with Phase 3. DeIDOT’s current best practice is to operate Phases 2, 4, 6, and 8 with dual entry at “8-phase” (concurrent) intersections.

5. System Compatibility

a. Uncoordinated Signals

This is a form of signal control in which an individual signalized intersection has neither control relationships between intersections nor any data flow between intersections. The individual isolated intersection may have local actuated control or Time of Day/Day of



Week changes based on historical traffic flows. This category has also been called isolated signal control and totally isolated systems.

b. Coordinated Signals

The potential benefits to be derived from the coordinated operation of two or more signalized intersections are directly related to the platoon arrival characteristics at the downstream intersection. If approaching vehicles arrive at the stop bar as a well-defined compact platoon, the coordinated operation can provide a significant reduction in stops and delays. The DE MUTCD suggests that signals spaced less than 1/2 mile apart should be coordinated because the cohesion of the platoon can be maintained for this distance.

The question of whether or not to coordinate a series of intersections is a complex decision. The prime objective is to assemble those intersections requiring similar timing strategies (i.e., cycle lengths and traffic flow patterns) into groups of reasonable size. The factors that need to be considered include:

- **Geographic relationship:** Distance between intersections; natural and artificial boundaries such as rivers and controlled-access facilities should be considered. Generally, signals within ½ mile of one another along a major route should be coordinated.
- **Storage:** The storage length between intersections is a very critical factor in the decision to interconnect traffic control signals. Closely spaced intersections should always be coordinated unless an engineering study recommends otherwise. In cases where queues extend from one intersection to another, signal coordination should be provided.
- **Volume levels:** The larger the mainline volume, the greater the need for coordination between signals.
- **Traffic flow characteristics:** If traffic arrivals are uniform throughout the cycle, the red portion of the cycle would produce the same stops and delays regardless of its position. On the contrary, platooned arrival enhances the benefits of coordination. When systems operating on different cycle lengths are adjacent to or intersect each other, changes to provide a uniform cycle length appropriate for both systems should be considered, so that the systems can be unified, at least for certain portions of the day. Half-cycles or double cycles should also be considered for some locations if that facilitates coordination.
- **Permissive Left Turns and Safety:** Drivers may have difficulty making permissive turning maneuvers at signalized intersections (e.g., permissive left turns, right turn



on red after stop) because of lack of gaps in through traffic. This can contribute to both operational and safety problems. Left-turning vehicles waiting to turn can block through traffic, even if a left-turn lane is provided. This can lead to rear-end crashes between turning and through vehicles. Crashes may also occur when left-turning drivers become impatient and accept a gap that is smaller than needed to complete a safe maneuver. Such crashes could be minimized if longer gaps were made available.

One method of providing longer gaps is to coordinate adjacent traffic control signals to promote platooning of vehicles. Signal progression can help improve driver expectancy of changes in right-of-way assignment due to signal changes. Increased platooning of vehicles can create more defined gaps of increased length for permissive vehicle movements at intersections and can result in improved intersection operation. Increased platooning of vehicles may also result in a decrease in rear-end crashes. Effective coordination of signals should reduce the required number of stops for the higher priority movements (presumably the major street through movement).

Table IV-7 below lists the potential benefits and drawbacks associated with providing signal coordination.

Table IV-7 Signal Coordination Benefits and Drawbacks		
Characteristic	Potential Benefits	Potential Drawbacks
Safety	Fewer rear-end and left-turn crashes.	May promote higher speeds.
Operations	Improves traffic flow.	Usually longer cycle lengths.
Multimodal	May reduce pedestrian-vehicle conflicts.	May result in longer pedestrian delays due to longer cycle lengths.
Physical	No physical needs.	None identified.
Socioeconomic	Reduces fuel consumption, noise, and air pollution.	None identified.
Enforcement, Education, and Maintenance	May result in less need for speed enforcement.	Signal timing plans need periodic updating.

Apart from its operational benefits, signal coordination is known to reduce vehicle conflicts along corridors where traffic control signals are coordinated. Largely, it reduces the number of rear-end conflicts, as vehicles tend to move more in unison from



intersection to intersection. Studies have proven the effectiveness of signal coordination in improving safety. The ITE *Traffic Safety Toolbox: a primer on Traffic Safety* cites two studies of coordinated signals with intersection crash frequencies that dropped by 25 and 38 percent. Selected findings of safety benefits associated with signal coordination are shown in **Table IV-8** on the following page.

Treatment	Finding
Signal Coordination	<ul style="list-style-type: none"> • 3 to 18% estimated reduction in all crashes along corridor • 14 to 43% estimated reduction in rear-end crashes along corridor
Provide Signal Progression	<ul style="list-style-type: none"> • 10 to 20% estimated reduction in all crashes along corridor

Once the decision is made to coordinate a series of intersections, there are a variety of ways to interconnect the controllers, using different forms of communication infrastructure. Coordination interconnection is typically accomplished using either fiber optic communication cables or telephone type cables with multiple conductors (6 pair, 12 pair, 18 pair, 25 pair).

There are some basic principles to be followed when installing coordination interconnect cables.

- i. All cables shall be terminated inside of an enclosure (control cabinet or computer building). This allows for easy termination on terminals and convenient testing points.
- ii. Intermediate splices should be avoided.
- iii. Do not place interconnect cables into the same conduit with cables that carry secondary line or higher voltage.

Grouping the signals to be coordinated is a very important aspect of design of a progressive system. Factors that should be considered include geographic barriers, volume-to-capacity ratios, and characteristics of traffic flow (random versus platoon arrivals).



c. Signal Pre-Emption / Priority

Section 4D.27 of the DE MUTCD discusses signal preemption, standards for the phases during preemption, and priorities for different vehicle types that might have preemption capabilities. A specific vehicle often targeted for signal preemption in Delaware is the emergency vehicle. Signal preemption allows emergency vehicles to disrupt a normal signal cycle to proceed through the intersection more quickly and under safer conditions. The preemption systems can extend the green on an emergency vehicle's approach or replace the phases and timing for the whole cycle. While several types of emergency vehicle detection technologies are available, the most commonly used preemption systems in Delaware consist of an emitter mounted on an emergency vehicle that sends an infrared pulse toward a detector mounted at the traffic signal, which is wired into the signal controller. Signal preemption detectors should be designed and installed on all approaches of DeIDOT-owned and maintained signals. The optical detectors should face "outside the box" – i.e., typically nearside closest to the stop line and facing approaching traffic (**Figure IV-13**).

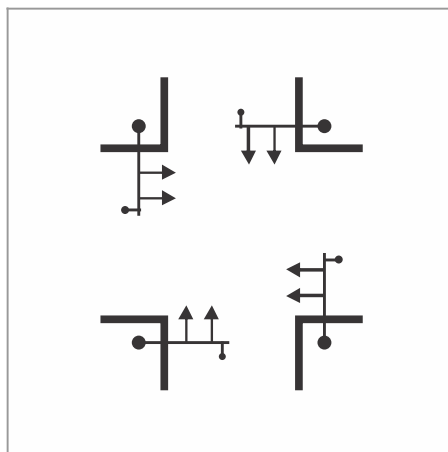

Figure IV-13. Placement of Optical Detectors

Sections 4D.27 and 8C.09 of the DE MUTCD include requirements and recommendations associated with traffic control signals located in the vicinity of grade crossings and, subsequently, railroad preemption. Because railroad preemption may cause excessive vehicular delays and/or abnormal traffic control signal operations for extended periods of time, the decision to install railroad preemption should not be made without consideration of other safety and operational alternatives. If an engineering study determines that railroad preemption is an appropriate countermeasure for a specific location, then the right-of-way transfer time, queue clearance time, and maximum



preemption time should be based on the TxDOT's *Guide for Determining Time Requirements for Traffic Signal Preemption at Highway-Rail Grade Crossings* (see **Appendix R**).

Where traffic signals at movable bridges are interconnected with signals at adjacent intersections, the traffic signals at the adjacent intersections should be preempted by the operation of the movable bridge. See Sections 4J.03 and 4D.27 of the DE MUTCD for additional guidance.

6. Pedestrians

a. Signal Guidelines

According to Section 4E.03 of the DE MUTCD, pedestrian signal heads **must** be used in conjunction with vehicular traffic control signals under any of the following conditions:

- If a traffic control signal is justified by an engineering study and meets either Warrant 4 - Pedestrian Volume or Warrant 5 - School Crossing (see DE MUTCD, Sections 4C.05 and 4C.06).
- If an exclusive signal phase is provided or made available for pedestrian movements in one or more directions with all conflicting vehicular movements being stopped.
- At an established school crossing at any signalized location.
- Where engineering judgment determines that multiphase signal indications (as with split-phase timing) would tend to confuse or cause conflicts with pedestrians using a crosswalk guided only by vehicular signal indications.

Pedestrian signals **should** be used under the following conditions:

- If it is necessary to assist pedestrians in making a reasonably safe crossing or if engineering judgment determines that pedestrian signal heads are justified to minimize vehicle-pedestrian conflicts.
- If pedestrians are permitted to cross a portion of a street, such as to or from a median of sufficient width to wait during a particular interval but are not permitted to cross the remainder of the street during any part of the same interval.
- If no vehicular signal indications are visible to pedestrians, or if the vehicular signal indications that are visible to pedestrians starting or continuing a crossing provide



insufficient guidance for them to decide when it is reasonably safe to cross, such as on one-way streets, at t-intersections, or at multiphase signal operations.

Pedestrian signals **may** also be installed under the following condition:

- When pedestrians cross part of the street, to or from an island, during a particular interval where they should not be permitted to cross another part of that street during any part of the same interval.

The DE MUTCD provides specific guidance on the type and size of pedestrian signal indications (Section 4E.04). As noted in the DE MUTCD, all new pedestrian signals should use the UPRAISED HAND (symbolizing DON'T WALK) and WALKING PERSON (symbolizing WALK) indications.

b. Timing Requirements

Pedestrian movements across signalized intersections are typically accommodated by one of the following options:

- Pedestrians cross the street with the parallel vehicular green indication (no pedestrian signal display). While this type of pedestrian accommodation may still be present at some older signals in Delaware, it should not be used for new signals or signal upgrades.
- Pedestrian movements are controlled by a concurrent separate pedestrian signal display. This is DelDOT's preferred method of accommodating pedestrians at signals.
- Pedestrians move on an exclusive phase while all vehicular traffic is stopped.
- A leading pedestrian interval to give the pedestrian(s) the opportunity to enter the roadway before traffic begins to move.

The essential factor in any of these options is to provide adequate time for the pedestrian to enter the intersection (walk interval) and to safely cross the street (pedestrian clearance interval). In cases where there are no separate pedestrian displays and the pedestrian moves concurrently with vehicular traffic on the parallel street, the time allocated to vehicular traffic must consider the time required for pedestrians to react to the vehicular green indication and move across the street.

When separate pedestrian displays (WALK, DON'T WALK) are used, the minimum WALK interval preferred by DelDOT is 7 seconds. This allows the pedestrian ample opportunity to leave the curb before the pedestrian clearance interval commences. Various research



studies have indicated that when there are fewer than 10 pedestrians per cycle, a WALK interval as short as 4 seconds may be used.

1.) Walking Speeds

Pedestrian walking speeds generally range between 2.5 ft/s and 6.0 ft/s. The DE MUTCD uses a walk speed of 3.5 ft/s for determining crossing clearance times. There are, however, various categories within the general population that walk at a slower rate. For example, very young children, the elderly, and people with disabilities may walk at a slower rate. Research on pedestrian characteristics verifies that 15% of all pedestrians walk at or below 3.5 ft/s. In general, to accommodate users who require additional time to cross the roadway, especially in lower speed areas where there are concentrations of children and or elderly persons, the minimum walk interval of 7 seconds may be increased to account for the need of slower pedestrians at known locations.

A general rule of thumb indicates that pedestrians at crossings are willing to wait only 30 seconds, at which point they will begin to look for opportunities to cross, regardless of the walk indication and the crossing location (reference 7, Chapter 18 of *HCM 2000*). Shorter cycle lengths benefit pedestrians, particularly where pedestrians often need to cross two streets at a time to travel in a diagonal direction, as well as drivers, who experience generally shorter delays.

2.) Minimum Clearance Times

Pedestrian timing requirements include a WALK interval and a flashing DON'T WALK interval. The WALK interval gives pedestrians adequate time to perceive the WALK indication and depart the curb before the clearance interval (flashing DON'T WALK) begins.

The DE MUTCD mandates that a pedestrian clearance interval always be provided and displayed long enough to allow the pedestrian who left the curb/edge of road (if no curb exists) during the WALK indication to travel from the curb/edge of road (if no curb exists) to the far curb or to a median of sufficient width for pedestrians to wait. Generally, the flashing DON'T WALK should be terminated and a steady DON'T WALK displayed at the onset of the yellow vehicular change interval. The minimum clearance interval is calculated by dividing the crossing distance (curb to curb) by the "normal" walking speed of 3.5 ft/s, as shown in the top equation of **Figure IV-14**.



Additionally, the sum of the walk interval and clearance time should allow a pedestrian walking at 3.0 ft/s to travel from the pedestrian detector to the far face of the curb/edge of road (if no curb exists). The equation to calculate this time is shown at the bottom of **Figure IV-14**. For additional information, refer to Section 4E.06 of the DE MUTCD.

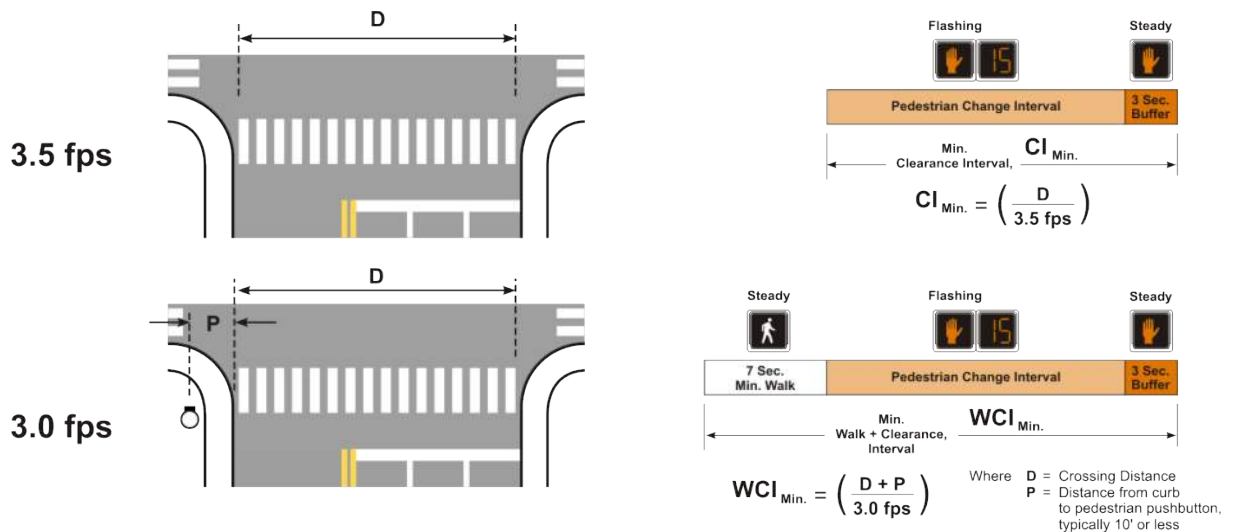

Figure IV-14. Clearance Interval Time Calculations

The recommended practice is for the pedestrian clearance time to be accommodated completely within the flashing DON'T WALK time.

During the transition to preemption, the WALK interval may be shortened or omitted.

c. Rest in Walk

When in a coordinated system, pedestrian phases operating concurrently with the major street through phases are programmed to “rest” in the corresponding walk interval. This operation allows the pedestrian walk interval to be extended to reduce the frequency of “jaywalking;” however, it adversely affects preemption transition times because shortening the pedestrian clearance interval is prohibited in Delaware.

d. Accessible Pedestrian Signals (APS)

Some signalized intersections have factors that may make them difficult for pedestrians who have visual disabilities to cross safely and effectively. As noted in the DE MUTCD (section 4E.09), these factors include:

- Increasingly quiet cars



- Right turn on red (which masks the sound of the beginning of the through phase)
- Continuous right-turn movements
- Complex signal operations (e.g., protected-permissive phasing, lead-lag phasing or atypical phasing sequences)
- Roundabouts
- Wide streets

To address these challenges, accessible pedestrian signals have been developed to provide information to the pedestrian in a nonvisual format such as audible tones, verbal messages, and/or vibrating surfaces. Detail on these treatments can be found in the DE MUTCD and in several references sponsored by the U.S. Access Board and the National Cooperative Highway Research Program (NCHRP).

When used, accessible pedestrian signals shall have an audible tone(s) during the WALK interval.

DelDOT will install APS upon request at a signalized intersection. Request forms are available online at DelDOT's webpage. To access the form, click on "Online Services" from the homepage, then select from the "A" column "Audible Pedestrian Traffic Signal Request."

e. Countdown Pedestrian Signals

All new and reconstructed traffic signals in Delaware will incorporate countdown pedestrian signals. See **Appendix S** for specific DelDOT timing guidelines. Redundancy in information to pedestrians benefits all pedestrians.

Countdown signals display the number of seconds remaining before the end of the DON'T WALK interval. Countdown displays shall not be used during the WALK interval, nor during the yellow change interval. The WALKING person symbol and flashing and steady UPRAISED HAND symbol still appear at the appropriate intervals, unless federally approved. The countdown signals do not change the way a signal operates; they only provide additional information to the pedestrian.

If the pedestrian change interval is interrupted or shortened as part of a transition into a pre-emption sequence, the countdown display should be discontinued and go dark immediately.



f. Alternative Pedestrian Phasing Options

Three options beyond standard pedestrian signal phasing are:

- The leading pedestrian interval
- The lagging pedestrian interval
- The exclusive pedestrian phase

A leading pedestrian interval entails retiming the signal splits so that the pedestrian WALK signal begins a few seconds before the vehicular green. As the vehicle signal is still red, this allows pedestrians to establish their presence in the crosswalk before the turning vehicles, thereby enhancing the pedestrian right-of-way.

A lagging pedestrian interval entails retiming the signal splits so that the pedestrian WALK signal begins a few seconds after the vehicular green for turning movement. The 2001 ITE guide, *Alternative Treatments for At-Grade Pedestrian Crossings*, indicates that this treatment is applicable at locations where there is a high one-way to one-way turning movement and works best where there is a dedicated right-turn lane. This benefits right-turning vehicles over pedestrians by giving the right turners a head start before the parallel crosswalk becomes blocked by a heavy and continuous flow of pedestrians.

An exclusive pedestrian signal phase allows pedestrians to cross in all directions at an intersection at the same time, including diagonally. It is sometimes called a "pedestrian scramble" phase. Vehicle signals are red on all approaches of the intersection during the exclusive pedestrian signal phase. The objective of this treatment is to reduce vehicle turning conflicts, decrease walking distance, and make intersections more pedestrian-friendly. However, exclusive pedestrian phases generally have a significant impact on intersection capacity and should be considered only in exceptional circumstances. The 2001 ITE guide refers to research that indicates that leading pedestrian phases were more effective treatments than exclusive pedestrian phases.

Leading pedestrian phasing may be considered where:

- There is moderate to heavy pedestrian traffic.
- A high number of conflicts/crashes occur between turning vehicles and crossing pedestrians.

Lagging pedestrian phasing may be considered where:

- There is moderate to heavy pedestrian traffic.



- There is right-turn channelization that is heavily used by vehicles.
- A high number of conflicts/crashes occur between right-turning vehicles and crossing pedestrians.

Exclusive pedestrian phasing (scramble) may be considered where:

- There is very heavy pedestrian traffic on all or most approaches.
- Delay for vehicular turning traffic is excessive due to the heavy pedestrian traffic.
- There is a large number of vehicle-pedestrian conflicts involving all movements.

Note that for any of the three treatments, the use of accessible pedestrian signals is recommended to give people with visual disabilities information of the walk phase in the absence of predictable surging traffic.

In rare circumstances, a 4-section T-shaped signal head with a solid red right turn arrow can be used in locations where right turns may be prohibited during certain phases per Sections 4D.22 of the DE MUTCD.